

# **SpectraVue User Guide**

**Ver. 3.00**

**Aug 4, 2009**

**MoeTronix**  
**[www.moetronix.com](http://www.moetronix.com)**

# Table of Contents

<b>1.</b>	<b>Introduction .....</b>	<b>4</b>
1.1.	<i>Block Diagram.....</i>	4
1.2.	<i>Functionality.....</i>	5
<b>2.</b>	<b>Getting Started .....</b>	<b>6</b>
2.1.	<i>Installing SpectraVue.....</i>	6
2.1.1.	Minimum System Requirements .....	6
2.1.2.	Program Installation .....	6
2.2.	<i>Installing USB Drivers.....</i>	6
2.2.1.	SDR-I4 USB Driver .....	6
2.2.2.	SDR-IQ USB Driver.....	8
2.3.	<i>Basic Program Operation .....</i>	9
2.3.1.	Main Screen .....	9
<b>3.</b>	<b>Program Details.....</b>	<b>10</b>
3.1.	<i>Top Menu Bar .....</i>	10
3.1.1.	File.....	10
3.1.2.	View.....	10
3.1.3.	Input Device .....	11
3.1.4.	Output Setup .....	18
3.1.5.	ExtRadioSetup .....	24
3.1.6.	General Setup .....	27
3.1.7.	Help.....	33
3.2.	<i>Plot Area .....</i>	33
3.2.1.	Raw Data.....	33
3.2.2.	2D Plot.....	34
3.2.3.	3D Plot.....	35
3.2.4.	V Waterfall.....	36
3.2.5.	H Waterfall.....	36
3.2.6.	Combo.....	37
3.2.7.	Continuum .....	38
3.2.8.	Phase .....	38
3.3.	<i>FFT Controls .....</i>	39
3.3.1.	FFT Ave.....	39
3.3.2.	FFT/BLK Size .....	39
3.3.3.	FFT Information.....	39
3.3.4.	V Scale .....	39
3.3.5.	Auto Scale Button .....	39
3.3.6.	Manual Vertical Slider Control.....	40
3.3.7.	NCO Null .....	40
3.3.8.	Smoothing .....	40
3.4.	<i>Frequency Controls.....</i>	42
3.4.1.	Main Frequency Control.....	42
3.4.2.	Span Frequency Control .....	43
3.4.3.	Frequency Lock Button .....	43

3.5.	<i>Start/Stop/Pause/Cont Controls</i> .....	43
3.6.	<i>Sound Card Audio Controls</i> .....	44
3.7.	<i>Demodulation Controls</i> .....	45
3.8.	<i>Memory Controls</i> .....	47
3.9.	<i>Status Bar</i> .....	48
<b>4.</b>	<b>Using With External Radios</b> .....	<b>49</b>
4.1.	<i>AOR AR5000</i> .....	50
4.2.	<i>Elecraft K3</i> .....	51
4.3.	<i>Yaesu FT-1000MP</i> .....	51
4.4.	<i>Yaesu FT-2000(with IF-2000 module)</i> .....	52
4.5.	<i>Icom IC-R8500, IC-R7000, IC-R7100, IC-R9000</i> .....	52
4.6.	<i>Ten-Tec Orion-2(with User IF modification)</i> .....	53
4.7.	<i>Icom IC-756PRO(with IF-2000 module)</i> .....	53
4.8.	<i>Kenwood TS-870</i> .....	54
4.9.	<i>Custom</i> .....	54
<b>5.</b>	<b>Timed Recording Formats</b> .....	<b>55</b>
5.1.	<i>RIFF .wav File custom Format</i> .....	55
5.2.	<i>FFT Absolute 2 byte Data .fft File custom Format</i> .....	56
5.3.	<i>Continuum .csv Format</i> .....	56
5.4.	<i>FFT Data Excel Comma separated.csv custom Format</i> .....	56
<b>6.</b>	<b>Pulse Mode</b> .....	<b>57</b>
<b>7.</b>	<b>Network Operation</b> .....	<b>58</b>
<b>8.</b>	<b>Hints and Tricks</b> .....	<b>61</b>
8.1.	<i>Frequency Calibration</i> .....	61
8.2.	<i>Amplitude Calibration</i> .....	65
8.3.	<i>Multiple Spectravue Instances</i> .....	65
8.4.	<i>Managing Frequency Memories</i> .....	66
<b>9.</b>	<b>External SpectraVue Control Messages</b> .....	<b>67</b>
9.1.	<i>Registered Message</i> .....	67
9.1.1.	<i>Example Message Handler</i> .....	67
9.1.2.	<i>Example Message Sending</i> .....	68
9.2.	<i>Available Command Definitions</i> .....	68

# 1. Introduction

SpectraVue is a Windows based program that takes digitized signal data from a variety of sources and displays the frequency domain spectrum on the PC screen. It can also be used to demodulate various signals and output them to a soundcard or wave file. The input data can come from a soundcard, a RIFF .wav file, or from special RF input capturing devices such as the SDR-14 or SDR-IQ. [www.rfspace.com](http://www.rfspace.com)

A few possible uses:

- General signal frequency domain analysis of spectra.
- Radio Astronomy applications where very weak wide bandwidth signals can be viewed with up to 30MHz bandwidth and a 254 Hz bandwidth resolution. (SDR-14 only)
- Demodulating various signals and viewing signal activity over a 190KHz bandwidth in real time.
- Storing and playing back sampled data for later analysis or demodulation.
- Panadapter connected to IF of wideband general coverage receivers.
- Unattended timed recording of spectra based on date/time and frequency.

## 1.1. Block Diagram

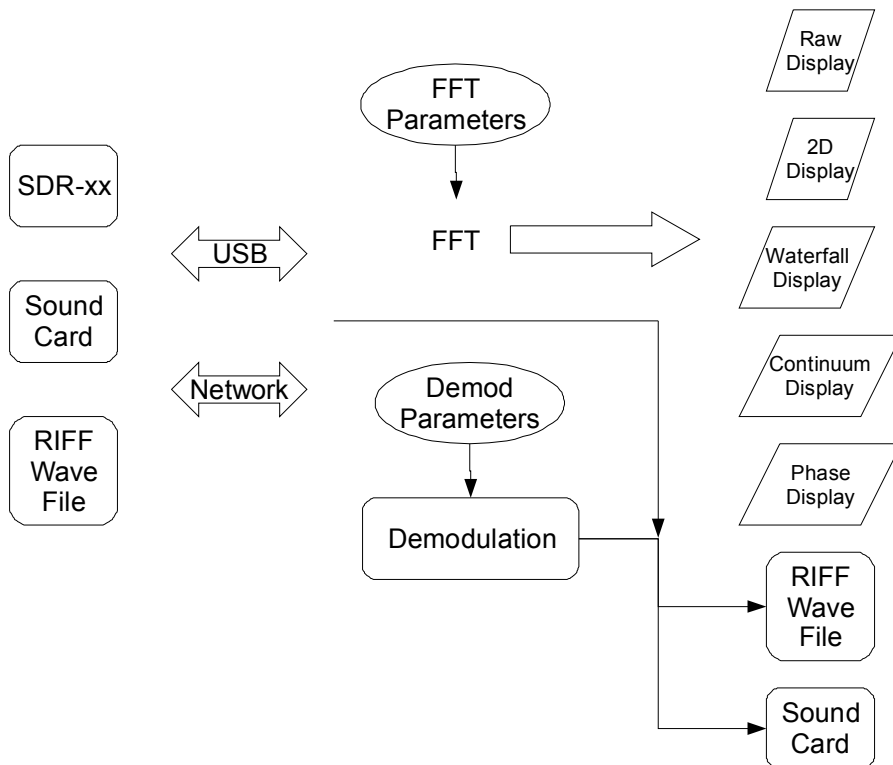

SpectraVue takes as input sources a variety of SDR-xx Software Defined Receivers from RFSpace, A PC Sound Card, or RIFF .wav file. The FFT (Fast Fourier Transform) is a math transform that converts the time domain data input samples into frequency domain data that is used for various display modes that show signal power versus frequency.

SpectraVue can also perform simple demodulation operations and output the audio to the sound card or a .wav file. The raw sample data from the input device can also be saved to a RIFF .wav file for later playback and analysis.

## **1.2. Functionality**

Basic program functionality includes the following features:

- FFT analysis using 2048 to 262144 point FFT's (real or complex).
- FFT amplitude resolutions from 10dB to .01dB per division.
- FFT amplitude power is in dBfs referenced to full scale (a single sine wave with an amplitude of +/-32767 or 16 bits).
- Various FFT data view modes including waterfalls and 2D and 3D plots.
- Display markers for accurate amplitude/frequency measurement.
- A continuum display for measuring spectral power over the entire span and/or the peak power within the span.
- Frequency Spans from 5KHz to 30MHz in various step sizes. (Using SDR-xx unit)
- Signal demodulation of AM, FM, WFM, USB, LSB, narrow CW modes when using the 50 to 190KHz Frequency Span and SDR-xx unit. Up to two separate demodulation channels can be active simultaneously.
- Programmable demodulation filters.
- Timed Saving and playback of captured spectrum using RIFF .wav files.
- Chaining of recording files both on saving and playback.
- IF/Panadapter mode that allows external radios to be used in front of the SDR-xx and maintain display frequency synchronization.
- A variety of file saving options ranging from saving the raw data to saving demodulated audio to saving various waterfall displays using .PNG or JPEG graphics file formats.
- Network Client for remote SDR-xx operation.
- 20 memory channels for quick save and restore of basic program settings.

## 2. Getting Started

### 2.1. Installing SpectraVue

#### 2.1.1. Minimum System Requirements

In order to utilize all the features of SpectraVue a 1GHz Pentium 2 or better with 128M of memory is required. Slower PCs can still be used if one is willing to accept slower displays and give up the real time demodulation features.

Windows XP or Win2K is required, Vista and later versions probably will work but have not been tested..

The graphics card is probably the single most important item for maximizing the full potential of SpectraVue and the SDR-xx. The faster the better and the more memory the better.

In the General Setup menu there is a "Slow CPU Mode" spin control that the user can adjust to adapt slower graphics cards/CPU's for best results. The tradeoff is that the display will skip updates to conserve CPU time.

#### 2.1.2. Program Installation

The SpectraVue distribution is contained in a single Setup.exe file. Execute this file from the CD or wherever it is located. The install program will run and step you through the process. One can choose alternate folders for the program and whether to automatically create a desktop icon and where to place the shortcut in the Startup Menu.

The installer will create three folders under the SpectraVue main folder.

The \SDR14USBdriver folder contains the USB driver required by the SDR-14.

The \SDRIQUSBdriver folder contains the USB driver required by the SDR-IQ.

The \Palettes folder contains several .pal files that are optional palette files used for the waterfall colors.

The \FilterComp folder contain optional .fcf filter compensation files used for flattening out the SDR-xx filter shapes.

The two main files for the program are "SpectraVue.exe" and a single dll file "IOModule.dll".

Several .ini files are included with some program settings for a few common modes. The file Spectravue.ini file is saved each time program exits and saves the users current settings.

The "spectravue.pdf" file is this help file which can be read using Acrobat Reader or similar programs.

### 2.2. Installing USB Drivers

The SDR-IQ and SDR-14 are USB devices and require a driver to be loaded before they can be used. The process is similar for each device. Install Spectravue BEFORE plugging in an SDR-xx device so that the drivers will be installed on your hard drive.

#### 2.2.1. SDR-I4 USB Driver

Connect the power supply to SDR-14 and connect the USB cable between one of your PC USB ports and the SDR-14. Your PC should recognize a new device being plugged in and pop up a driver installation menu.

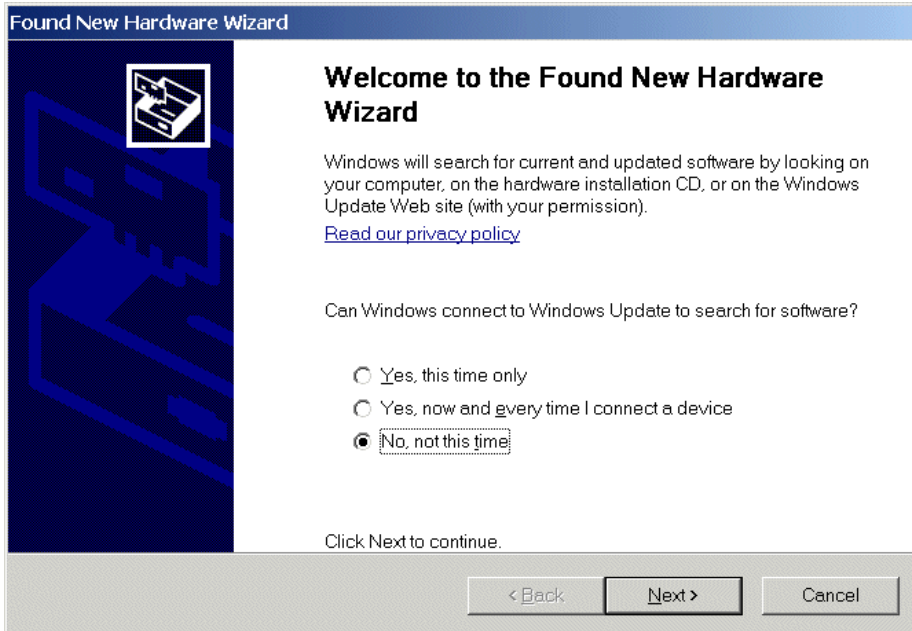

Select No, not this time to allow choosing the driver file location.

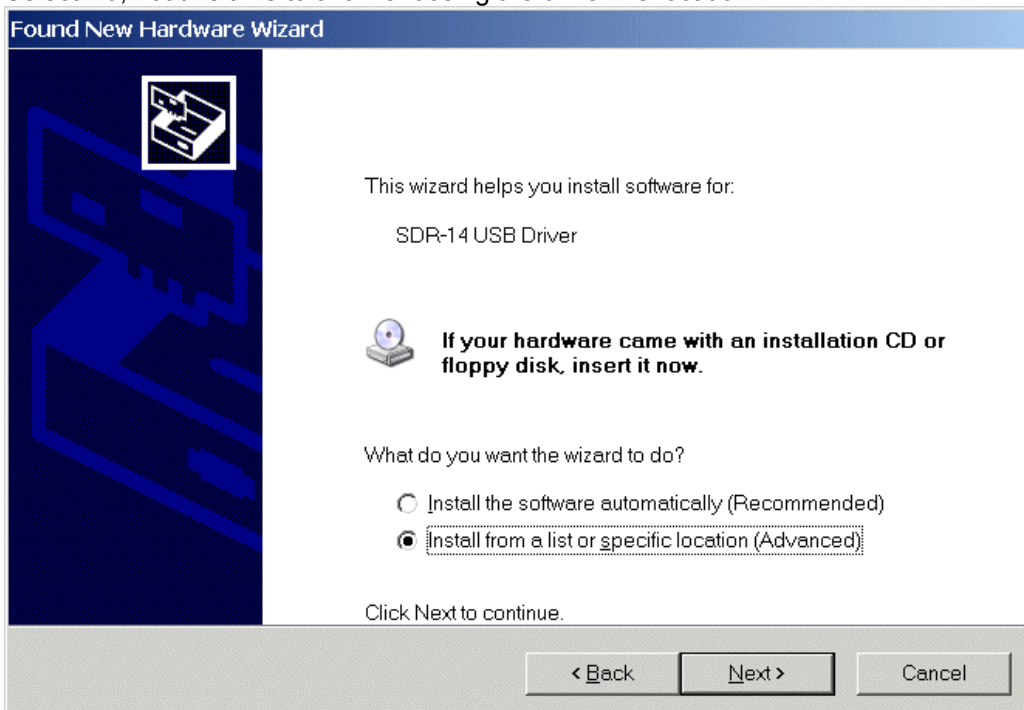

Choose to Install from specific location.

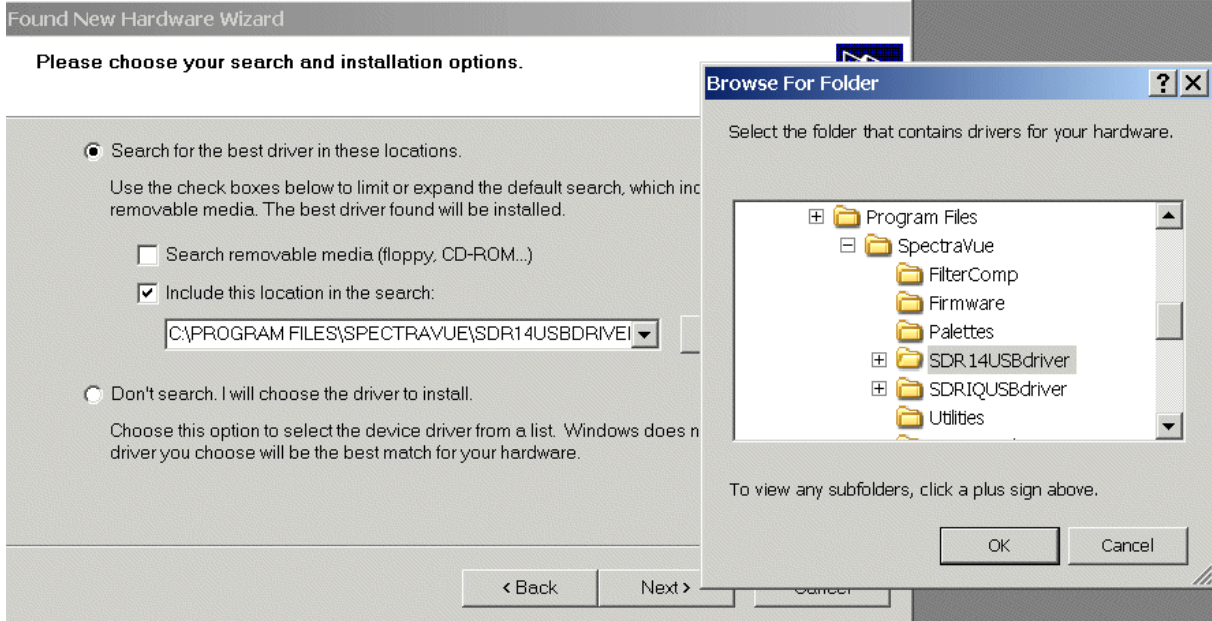

Browse to the Program Files\Spectavue\SDR14USBdriver folder and click OK.



Continue anyway since the driver is not a Microsoft driver.

The driver should load and then this process will repeat itself as the driver is a dual driver. The procedure is the same.

### 2.2.2.SDR-IQ USB Driver

Connect the USB cable between one of your PC USB ports and the SDR-IQ. Your PC should recognize a new device being plugged in and pop up a driver installation menu.

The SDR-IQ uses a USB driver that is common to a lot of FTDI based products so it may already be installed on your PC in which case it should just install automatically. If not, then the same procedure should be used as with the SDR-14 except you would choose the SDRIQdriver folder when prompted.



## 2.3. Basic Program Operation

Click on the desktop Icon for Spectravue or go to the Windows Start menu to launch Spectravue. If the SDR-xx is connected the status in the bottom status bar should say "Idle" and you can click on the "Start" button or press "F12" to begin operation.

### 2.3.1. Main Screen

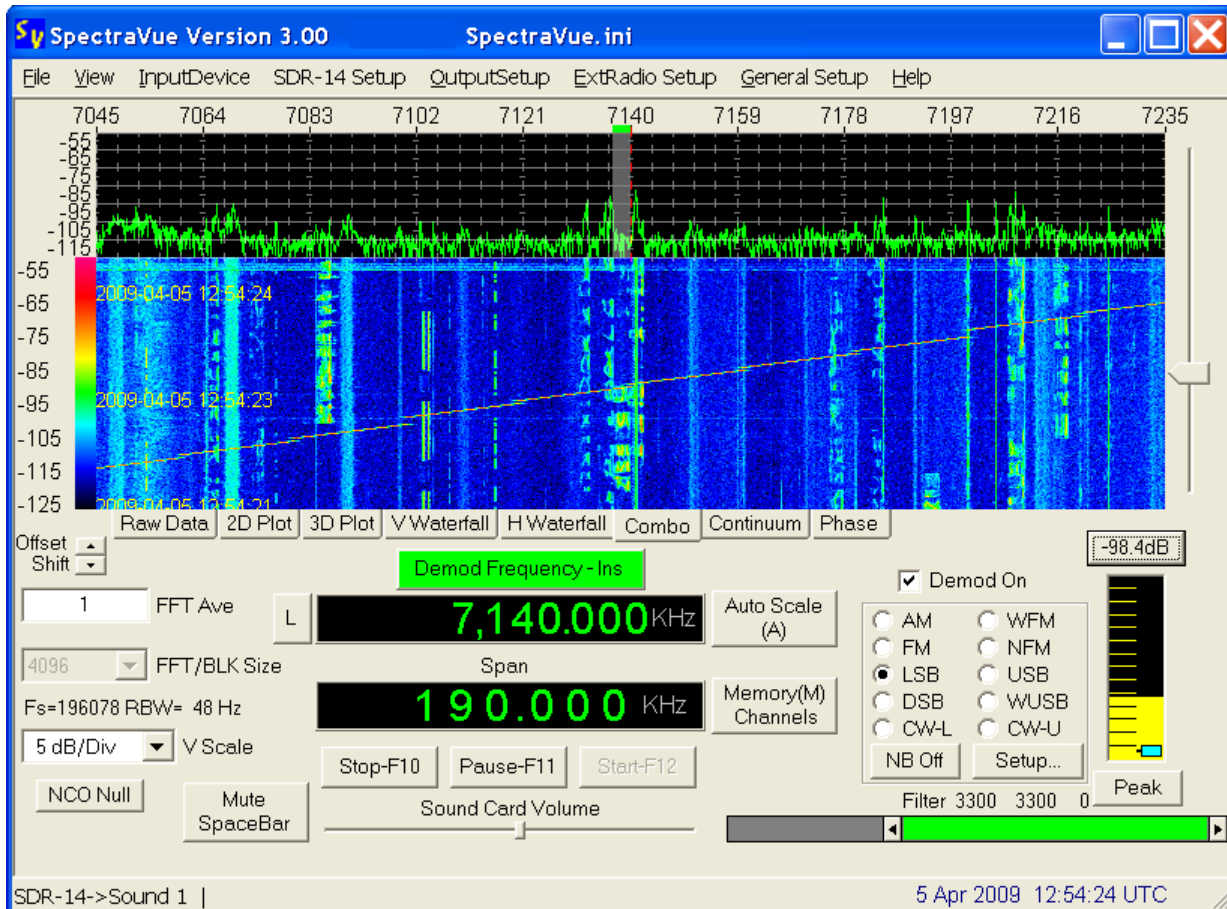

The Main Screen should look similar to this when first run. The receive center frequency can be changed by clicking in the main display area, using the mouse scroll wheel, or entering the frequency digits directly into the frequency control.

The "Auto Scale" button can be pressed (or the "A" key) to automatically place the spectrum display in viewing range.

Various signal views are possible by clicking on the desired TAB under the display area such as V Waterfall, Combo, etc. Audio volume can be changed using the sound card slider control or just use your normal PC audio controls.

One can just start experimenting with all the controls or better yet, browse through the next section to get an idea of all the functionality of the program.

### 3. Program Details

The following sections provide detailed explanations for all the various menus and program controls.

#### 3.1. Top Menu Bar

##### 3.1.1. File



#### Load/Save Setup

These menu items allow the user to save all the program setup information into an .ini file that can be uniquely named and loaded into the program later to restore the particular settings saved in the file. This allows the user to create a library of various custom setups that can then be quickly loaded without having to setup all the various options again. The most recently used file list can be clicked on to recall the last several ini files that have been used.

Note that the file Spectravue.ini is the primary file for saving your settings when exiting the program and will be overwritten each time the program is exited. It is loaded automatically when the program is first executed.

#### Save FFT to Excel File

This menu item allows the current raw FFT data to be saved to a comma-separated file that can be imported into a spreadsheet for further analysis or graphing. The file contains 2 columns. The first column is the frequency in Hz and the second is the amplitude in dB relative to full scale. This only saves one FFT block of data that was the last one captured.

#### Save Screen Graphics File

This menu item allows the current screen to be saved to a graphics file. The format can be .png, .bmp, or .jpg.

#### Print/Print Setup/Print Preview

These menu items are used to invoke the Windows printer functions. The current screen can be printed out. One must stop or pause the capturing process before printing or the screen may not print as expected.

##### 3.1.2. View

The view menu allows the user to hide the bottom status bar and/or force the program to always be on top of the desktop.

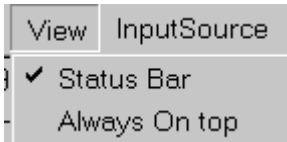

### 3.1.3. Input Device

This menu item allows the selection of a data input source. Currently 5 sources are available.

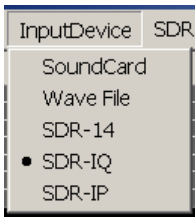

#### SDR-xx / SoundCard In / WaveFile In Setup

The Input setup menu depends upon the input source selected.

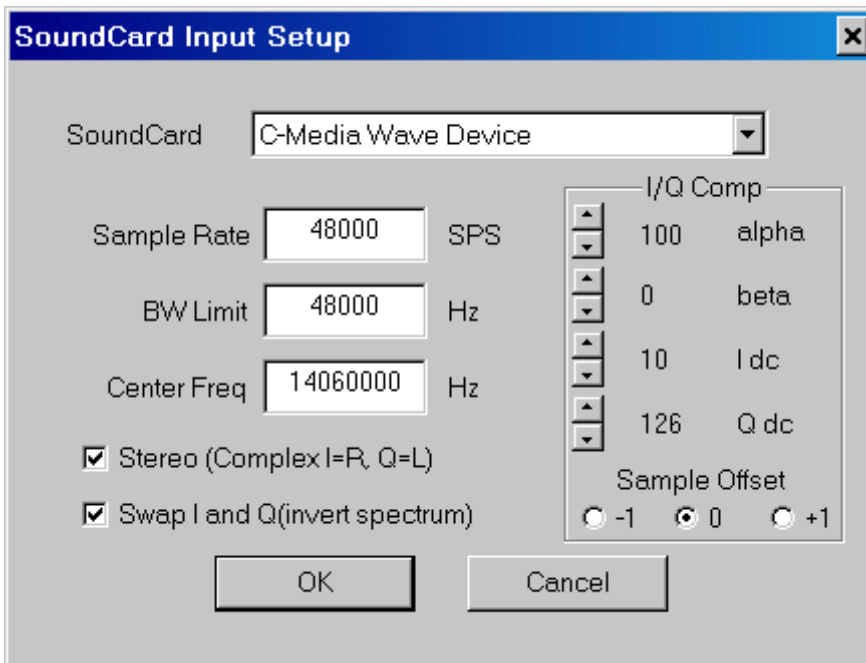

- The Soundcard can be selected with the pull down menu or one can use the default Windows soundcard.
- The sample rate must be specified and can range from 5000 to 96000 SPS. (Many soundcards will not operate above 48000 SPS)
- The bandwidth limit depends upon whether the Stereo (Complex) mode is chosen. The maximum BW is the sample rate if Complex or 1/2 the sample rate if mono (real) data.
- The Center frequency is an offset that is applied to the display. This is useful in applications where the soundcard is used to process base band I/Q inputs from complex mixers. The Center frequency would be the mixer oscillator frequency.
- The Swap I/Q button can swap the left and right channels that will invert the spectrum.

- The I/Q Comp section is used to adjust for DC offsets in the I/Q channels. By watching the Raw Data display (center number is DC offset) one can minimize the DC offset. Adjust the I offset to make the Green line closer to zero and the Q offset to make the red line closer to zero. The affect of a DC offset is a large spur in the center of the 2D FFT display.
- The alpha and beta controls can be used to compensate for any phase errors between the I and Q channels. The affect of a phase error is a reduction in sideband rejection. (A carrier will appear mirrored on the opposite side of the FFT display)
- The Sample Offset is a gross adjustment in case a soundcard is off by a complete sample between the I and Q channels. (One USB soundcard chip has a bug so that I and Q are one sample time apart.)

### Wave File In setup

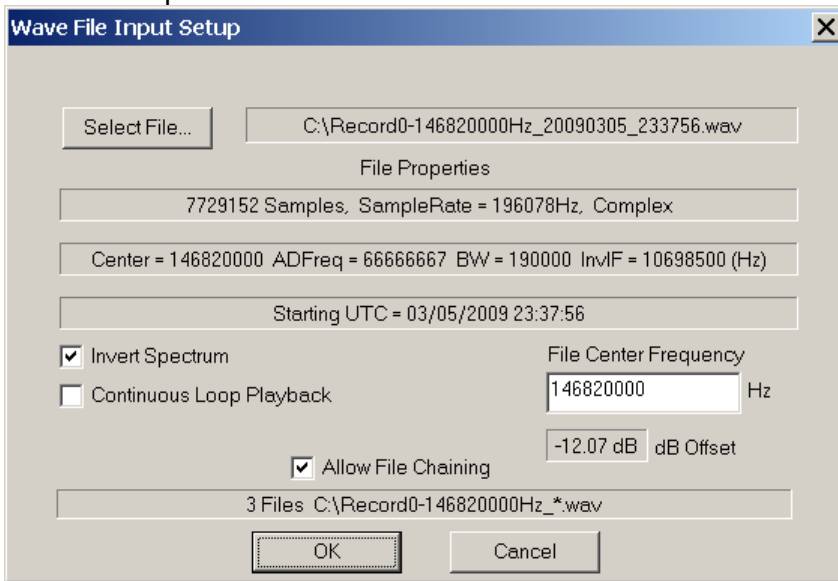

- The Wave file input menu allows the user to specify the wave file path and also whether to invert the spectrum or play the file back in a continuous loop.
- Depending on the file, several parameters are displayed along with the name. The first line shows the file size in samples, the file sample rate, and whether the data is real or complex.
- The second line may show the captured data center frequency, the A/D frequency, and display bandwidth if the SDR-xx was used to generate the wave file.
- The third line may show the capture starting time if the file was created with SpectraVue. This is used to show the original UTC time when playing back wave files. Note that if a capture was paused or the center frequency changed during creation, then the file data will not be correct for the entire file.
- Allow File Chaining will allow multiple .wav files to be played in sequence automatically with the same base file name.

Wave files created with a program other than SpectraVue will not contain some of the above information. Currently .wav files from SpectraVue, PowerSDR, and the Perseus are supported.

## SDR-14 Setup

This setup menu is used to set the main parameters of the SDR-14 hardware.

- The A/D Sample Frequency can be entered here. Nominally it is 66,666,667Hz but this number can be changed to the actual oscillator frequency if more accurate frequency measurements are desired.
- There are 13 fixed bandwidth setups that can be chosen. If the 30MHz bandwidth is selected, the AD6620 down converter is bypassed and the entire 33.3 MHz wide A/D data is directly processed by SpectraVue using a real mode FFT.

**Note that for demodulation, only the 50KHz to 190KHz bandwidths can be used. Some PC's may not be able to use the 190KHz mode as it pushes the USB bus to the limit.**

The AD6620 settings area of the screen displays the current AD6620 decimation rates and filter sizes. The AD6620 IF gain can be selected from 0 to +24dB in 6dB steps. This value is best kept at +24dB unless very strong signals are being analyzed and the SDR-14 is being overloaded.

- The input source can be selected as either direct to the A/D (ch0) or through a preamp and a 30MHz low pass filter (ch1).

**Note The direct A/D input should not be directly connected to an antenna. It requires a bandpass filter and preamp in order to be used as a harmonic sampling receiver above 30MHz. It is also not protected from voltage spikes and ESD events.**

- If ch1 is used, the preamp/attenuator RF gain can be selected. The "Calibrated screen" check box forces the display to remain calibrated regardless of RF gain setting.
- If the red clipping light flashes on the SDR-14, use the Channel 1 RF Gain setting to add attenuation until the red light does not flash. ( it is normal for a random flash to occur during normal operation due to transients on the antenna)

- If the Network Interface is selected, the edit boxes for the desired IP and port addresses are used to specify the IP address and port. This feature is an option and requires a separate USB to TCP/IP Server application running to be able to use.
- The Firmware update button enables a menu to update the SDR-14's internal firmware. One opens the update .hex file and presses Start to begin the firmware update. The SDR-14 must be attached and powered up for this menu to be used.

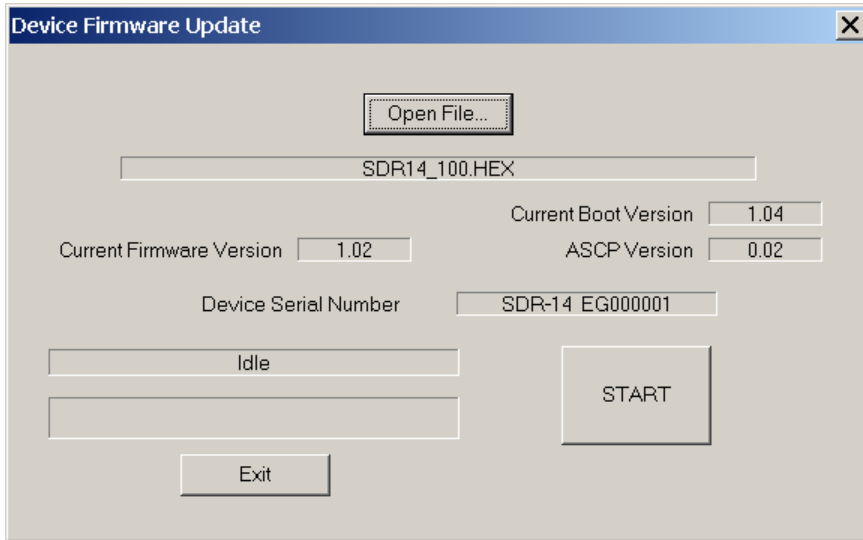

- The External HW Sync should remain unchecked for normal operation of the SDR-14.

## SDR-IQ Setup

This setup menu is used to set the main parameters of the SDR-IQ hardware.

- The A/D Sample Frequency can be entered here. Nominally it is 66,666,667Hz but this number can be changed to the actual oscillator frequency if more accurate frequency measurements are desired.
- There are 7 fixed bandwidth setups that can be chosen. **Note that for demodulation, only the 50KHz to 190KHz bandwidths can be used. Some PC's may not be able to use the 190KHz mode as it pushes the USB bus to the limit.**

The AD6620 settings area of the screen displays the current AD6620 decimation rates and filter sizes. The AD6620 IF gain can be selected from 0 to +24dB in 6dB steps. This value is best kept at +24dB unless very strong signals are being analyzed and the SDR-IQ is being overloaded.

- The RF Gain selection allows using fixed 10dB step settings or one can enter a variable value for the preamp. A separate 10dB fixed attenuator can be activated along with the variable gain preamp. Note that high gain preamp settings will not improve the receiver noise figure above a certain level but will just raise the noise floor and reduce the dynamic range.
- If the Network Interface is selected, the edit boxes for the desired IP and port addresses are used to specify the IP address and port. This feature is an option and requires a separate USB to TCP/IP Server application running to be able to use.
- The Firmware update button enables a menu to update the SDR-IQ's internal firmware. One opens the update .hex file and presses Start to begin the firmware update. The SDR-IQ must be attached and powered up for this menu to be used.

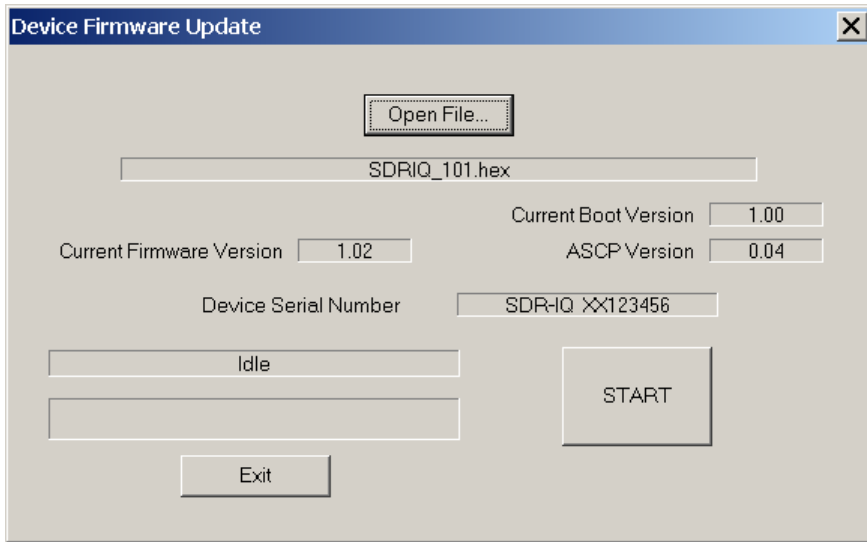



## SDR-IP Setup

Preliminary setup screen for a future product.

### 3.1.4. Output Setup

The Output setup menu contains setup items pertaining to the output modes and options of SpectraVue.

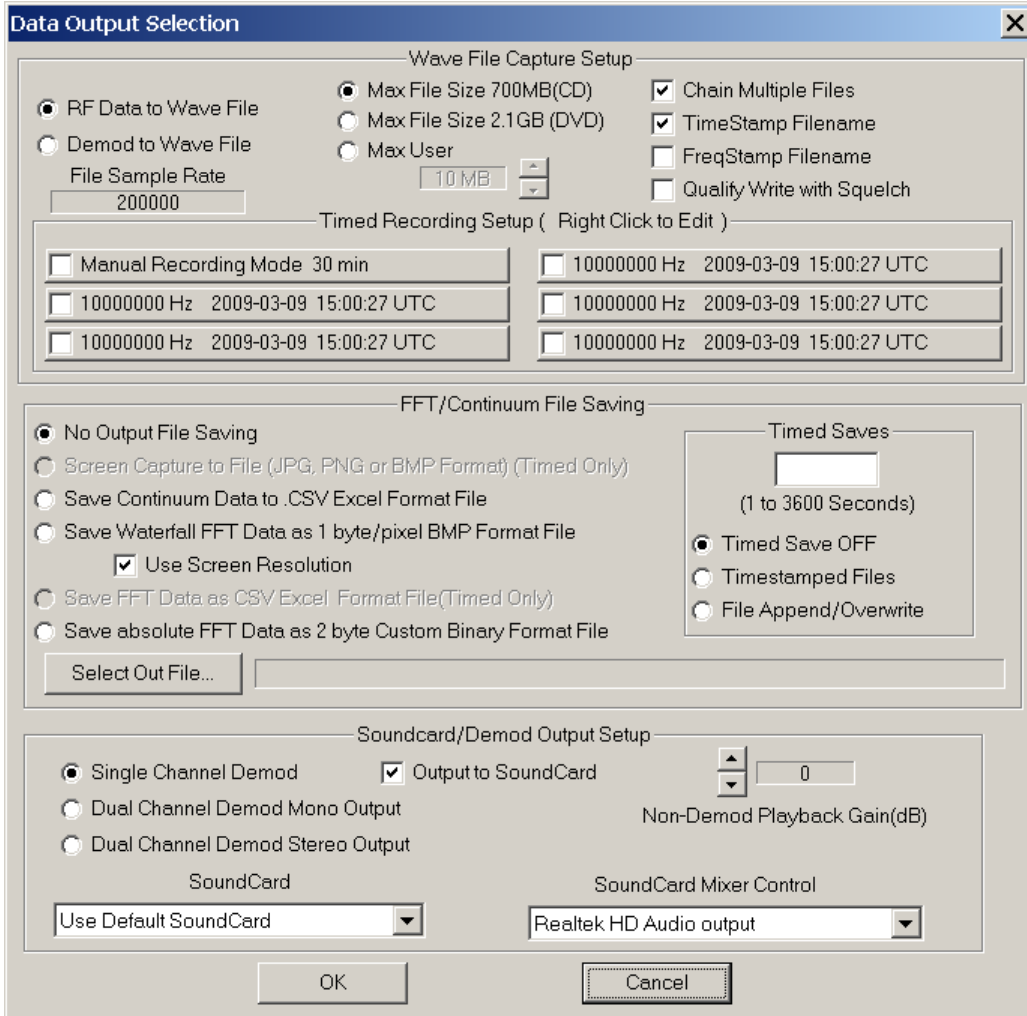

#### Wave File Capture Setup

The top section of the menu contains wav file capture setup items.

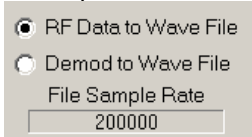

These two buttons select whether the raw RF data samples are saved to the .wav file or if the demodulated audio samples are saved to the file. The file sample rate is shown in the text box.

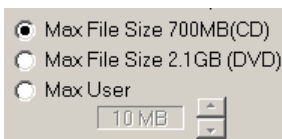

There are three selections that can be used to limit the individual .wav file size to a maximum number of bytes.

This is useful so the files will fit on CD's or DVD's. A user adjustable maximum can be set to break up the file sizes into custom sizes.

<input checked="" type="checkbox"/>	Chain Multiple Files
<input checked="" type="checkbox"/>	TimeStamp Filename
<input type="checkbox"/>	FreqStamp Filename
<input type="checkbox"/>	Qualify Write with Squelch

These check boxes are used to specify various options in .wav file saving.

Enabling Chain Multiple Files will cause SpectraVue to continue recording for the specified amount of time and break the files into multiple files automatically. If it is not enabled, SpectraVue will record until the maximum file size is reached and then stop.

Checking the Qualify with Squelch box will cause the data to be saved only when the squelch control is active. This is useful for recording only when signals are present.

The TimeStamp Filename and FreqStamp Filename check boxes will enable modes to append to the base filename the center frequency and/or the time date information.

For example suppose the base filename is MyFile.wav and the center frequency is 1.234567MHz:

If only the Chain Multiple Files is checked the file names will be MyFile\_nnn where nnn is just a sequence of numbers 000 to 999.

If the FreqStamp is enabled the file names will be MyFile-1234567Hz\_nnn.wav

If the TimeStamp is also enabled the file names will be MyFile-1234567Hz\_YYYYMMDD\_HHmmSS.wav

Where YYYY is the UTC year

MM is the month 01 to 12

DD is the day of month 01 to 31

HH is the hour in 24 hr format

mm is minutes 00 to 59

SS is seconds 00 to 59

### Timed Recording menu

The Timed recording menu section contains 6 buttons that control one manual record mode and 5 automatically time record modes.

Timed Recording Setup ( Right Click to Edit )	
<input type="checkbox"/> Manual Recording Mode 30 min	<input type="checkbox"/> 10000000 Hz 2009-03-09 15:00:27 UTC
<input checked="" type="checkbox"/> 16220000 Hz 2009-03-12 15:47:06 UTC	<input type="checkbox"/> 10000000 Hz 2009-03-09 15:00:27 UTC
<input checked="" type="checkbox"/> 88990000 Hz 2009-03-25 15:47:31 UTC	<input type="checkbox"/> 10000000 Hz 2009-03-09 15:00:27 UTC

Left clicking on the button will enable or disable the button which is indicated by a checkmark on the button.

The button text indicates the center frequency and start time/date setup of that button.

Right clicking on the button brings up the setup menu for that button.

### Manual Record Mode

Note that is Manual Record mode is enabled, the automatic record buttons are disabled.

Timed Recording Setup ( Right Click to Edit )	
<input checked="" type="checkbox"/> Manual Recording Mode 30 min	<input type="checkbox"/> 10000000 Hz 2009-03-09 16:00:39 UTC
<input type="checkbox"/> 16220000 Hz 2009-03-12 15:47:06 UTC	<input type="checkbox"/> 10000000 Hz 2009-03-09 16:00:39 UTC
<input type="checkbox"/> 88990000 Hz 2009-03-25 15:47:31 UTC	<input type="checkbox"/> 10000000 Hz 2009-03-09 16:00:39 UTC

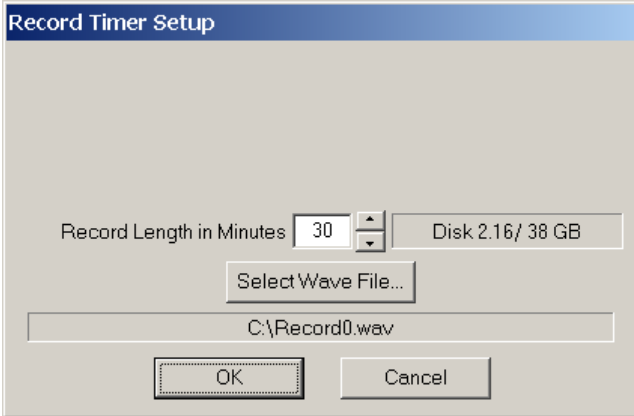

The manual record mode only sets the file root name and the maximum recording time. The disk space requirements are estimated based on the time limit and current file sample rate.

When the manual record mode is enabled, a new control button will be visible next to the main Start Button as soon as the Start Button is pressed. The data is not automatically saved to the manual .wav file until the Record button is pressed.

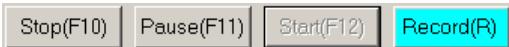

After the Record Button is pressed, the data will be saved to the file until the Record button is pressed again, the time limit expires, or the Stop Button is pressed.

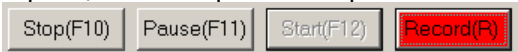

This mode allows one to quickly start and stop the .wav file saving without having to stop the overall process. A new file is created each time the Record button is toggled allowing frequency changes to be made.

**Automatic Timed Record Mode**

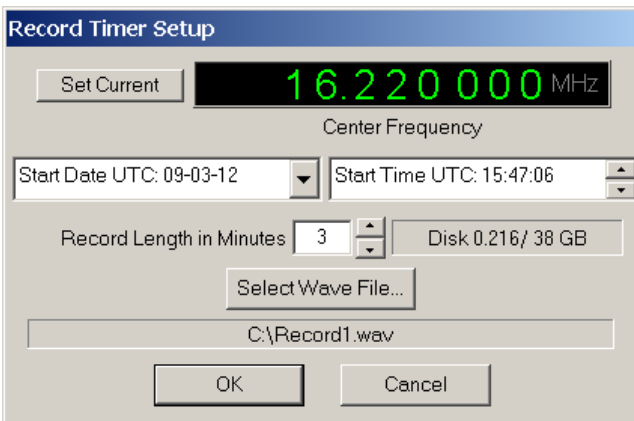

The automatic timed record setup requires the user to select the center frequency, the starting date and time in UTC as well as the run time in minutes and base filename.

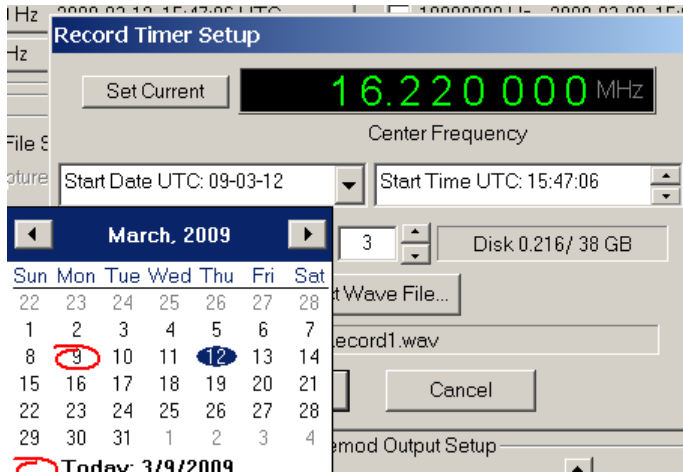

The starting date is selected by clicking on the desired date on the calendar control.



The starting time is modified by clicking on the Hour, Minute, or Seconds field then either entering a number with the keyboard or use the up/down arrow keys to set the start time in UTC.

Obviously the starting date and time must be in the future. Remember to enable the recording button by clicking on the button until it is checked. Multiple buttons can be enabled at the same time. If any recording times overlap then the first one will finish its time slot then the overlapped time slot will record whatever time is remaining.

#### Screen Capture to File

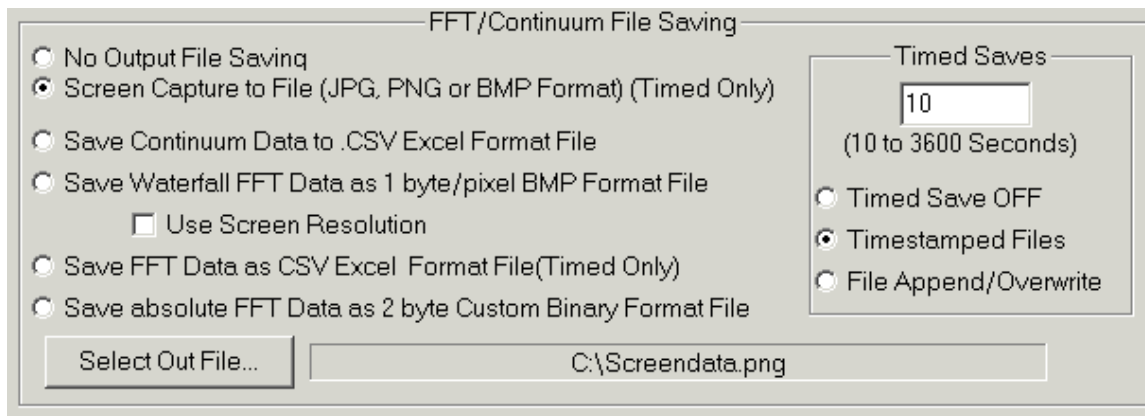

This option is only valid when the timed save mode is active.

Selecting this file saving option will capture the screen every N seconds to a time stamped file or it will overwrite the selected file each time. Either .png or .jpg graphics formats are supported. In general, the .png works best for everything except the waterfall displays where the .jpg works best.

## Save Continuum Data as .CSV Excel Format File

FFT/Continuum File Saving

No Output File Saving  
 Screen Capture to File (JPG, PNG or BMP Format) (Timed Only)  
 Save Continuum Data to .CSV Excel Format File  
 Save Waterfall FFT Data as 1 byte/pixel BMP Format File  
     Use Screen Resolution  
 Save FFT Data as CSV Excel Format File(Timed Only)  
 Save absolute FFT Data as 2 byte Custom Binary Format File

Timed Saves  
10  
(10 to 3600 Seconds)  
 Timed Save OFF  
 Timestamped Files  
 File Append/Overwrite

Select Out File... C:\Continuum.csv

This menu specifies a comma-separated file that will be written with timestamp information, average continuum data and peak continuum data. The following is an example of the data format:

```
12/02/2003 17:23:01, -108.132, -63.530954  
12/02/2003 17:23:06, -108.457, -75.24949  
12/02/2003 17:23:11, -108.143, -69.852774
```

## Save Waterfall Data as 1 byte/pixel BMP Format File

FFT/Continuum File Saving

No Output File Saving  
 Screen Capture to File (JPG, PNG or BMP Format) (Timed Only)  
 Save Continuum Data to .CSV Excel Format File  
 Save Waterfall FFT Data as 1 byte/pixel BMP Format File  
     Use Screen Resolution  
 Save FFT Data as CSV Excel Format File(Timed Only)  
 Save absolute FFT Data as 2 byte Custom Binary Format File

Timed Saves  
10  
(10 to 3600 Seconds)  
 Timed Save OFF  
 Timestamped Files  
 File Append/Overwrite

Select Out File... C:\Waterfall.bmp

This menu specifies a 1 byte per pixel .BMP graphics file of the waterfall display to be written. If the "Use Screen Resolution" box is checked, the image width will be the same as the screen pixel width. This mode creates images that are the same size as the program screen for easy viewing and reduced file size.

If not checked, the image width will be the number of the FFT points within the specified frequency span. This mode can create very wide images depending on the FFT size and span but provides much greater detail than can be obtained on a CRT screen.

The graphics files are limited in size by the Output Size limit. Many graphics programs are limited to how large an image can be displayed as well. Keeping the file size below 100MB is probably a prudent step.

## Save FFT Data as .CSV Excel Format File

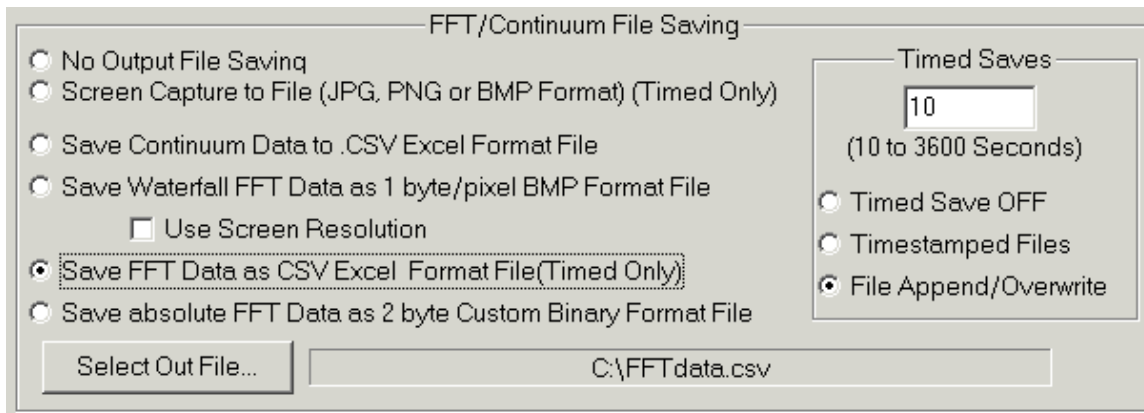

This mode is only available in the timed save mode. Every N seconds, the entire FFT data values are saved to a .CSV format file.

The first row of comma separated data is the frequency of each FFT bin in Hz.

The second row is the amplitude information in dB for each FFT bin.

Its best to keep the FFT size as small as possible since Excel can get overwhelmed with large data arrays very quickly.

## Save Absolute FFT Data as 2 byte binary format file

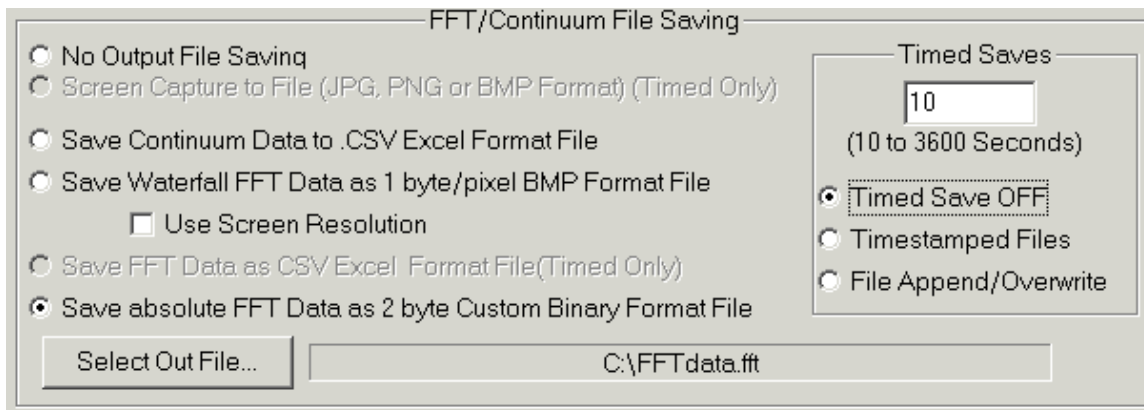

This menu specifies a custom 2-byte binary format file that will be written with the raw FFT data.

The File format is a 1024 byte header containing the following information:

Number data points per FFT = 32 bit value Little Endean byte format

FFT size = 32 bit value Little Endean byte format

FFT sample rate in Hz = 32 bit value Little Endean byte format

FFT center frequency = 32 bit value Little Endean byte format

The remaining bytes in the 1024 byte header are 0.

Starting at file location 0x400(1024) the FFT data is placed as a 2 byte signed integer that represents the FFT data times 100. So for example a -135.23dB point would be saved as a 16-bit integer -13523, Little Endean word. All FFT points are saved regardless of the span so the next FFT line would begin at 0x400 + FFTSIZE\*2 for real FFTs or 0x400 + FFTSIZE\*4 for complex FFTs.

## Soundcard/Demod Output Setup

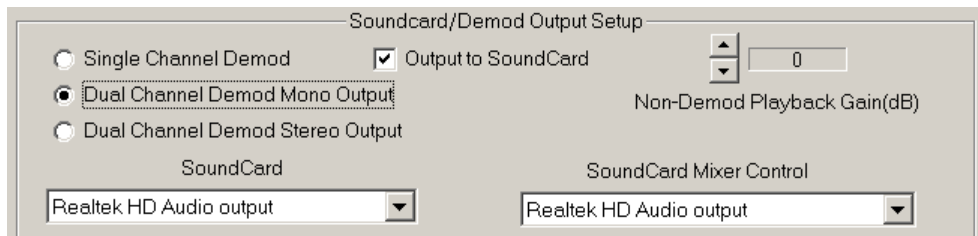

The Soundcard output menu allows enabling the soundcard for output. This is primarily for listening to demodulated signals but can also be used in playing back wave files or listening directly to I/Q data if the soundcard supports the input sample rate.

The Soundcard selection menu allows selecting a particular soundcard for multiple soundcard systems.

The Soundcard Mixer selection menu allows selecting a particular soundcard mixer to use as the volume control.

The non-demod playback gain control allows the audio to be scaled. This is active only when demodulation is not active, the sound output is selected, and the sample rate is less 200KHz. This is useful for amplifying a captured RF file to a level that can be heard or for retransmission out the soundcard as I/Q data.

The Demodulator has up to 2 channels. If the “Single Channel Demod” box is selected, then only one demodulator is used and is output to both Left and Right Speakers.

If the “Dual Channel Demod Mono Output” box is selected, then both demodulators are used and combined into one mono audio stream to both Left and Right Speakers.

If the “Dual Channel Demod Stereo Output” box is selected, then both demodulators are used and each demodulator audio stream is sent separately to the Left and Right Speakers.

### 3.1.5.ExtRadioSetup

This menu is used for external radio setup when a separate radio is used to extend the frequency range of the SDR-xx or to use as a Panadapter.

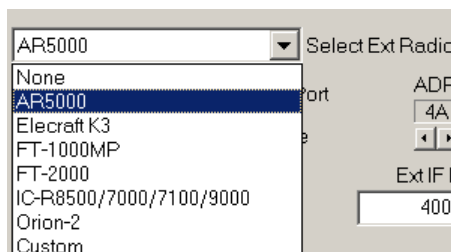
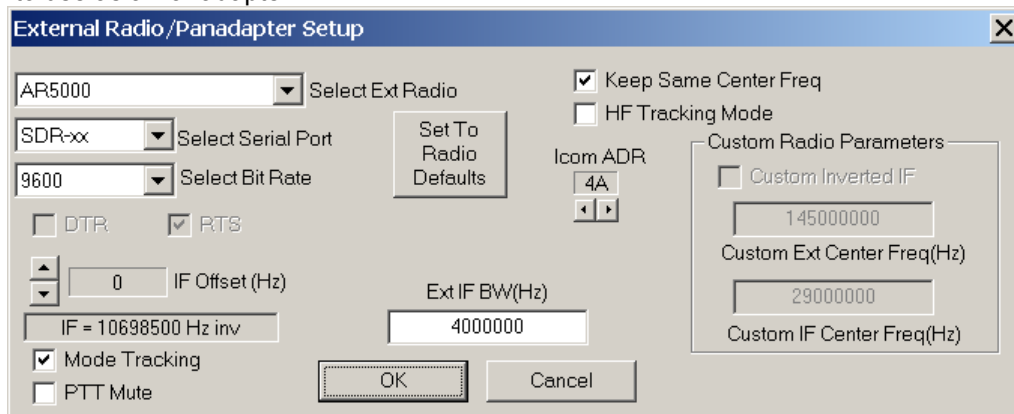



Several radios are directly supported that allow communication between SpectraVue and the radios that the frequency settings track each other. Normally the radio has an IF output that is fed into the SDR-xx and is automatically set up as to frequency and whether it's spectrum is inverted or not.

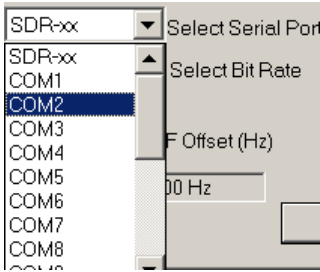

The Select Serial Port menu selects the desired PC COMx port if you wish to use a PC COM port. The SDR-xx selection can be used to select the built in serial port of the SDR instead of the PC COM port. Not all models have this capability.

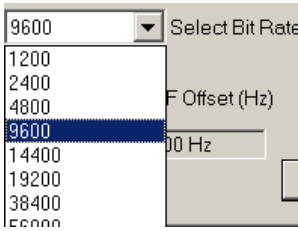

The Bit (Baud) rate can be selected and must match that of the external radio.

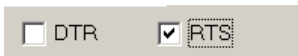

The PC serial port HW handshaking lines DTR and RTS can be manually set using these two check boxes. These may be needed for some CAT interfaces that use the RS-232 port for power.

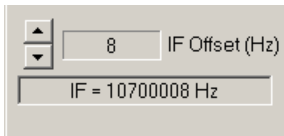

The IF frequency of the radio can be offset by +/- Hz some amount in order to compensate for any frequency errors in the radio.



Pressing the “Set To radio Defaults” button will set some defaults such as Bitrate, Icom radio address, and IF Bandwidth.

**( Note: Some of the multiple selections for the Icom radios will set the radio default address for only one of the radios so you will have to manually set depending on your particular model. See list below. )**



ICOM radios require a communications interface address and it can be selected using the spinner control. It must match that of the radio.

Currently Supported Icom radio addresses:

IC-756 = x50 IC-756PRO = x5C IC-756PROII = x64 IC-756PROIII = x6E  
IC-7000 = x08 IC-7100 = x34 IC-8500 = x4A IC-9000 = x2A

The Ext IF BW edit box allows the user to specify what the useable bandwidth of the radio IF. This can be used to limit the IF to regions that are more flat or that do not contain as many spurious signals.

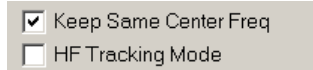

Keep Same Center Freq  
 HF Tracking Mode

These two selections select the mode of operation of the external radio setup.

“Keep same Center Freq” forces SpectraVue and the external radio to keep the same center frequency. If not selected then the SDR-xx can independently tune within the external radio’s IF bandwidth.

“HF Tracking Mode” is used when a radio does not have an IF output so both the external radio and the SDR-xx can tune the same frequency within the 0 to 30MHz HF band. The SDR-xx and external radio should both be connected to an HF antenna for this to work.

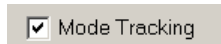

Mode Tracking

If Mode Tracking is selected then SpectraVue attempts to track the demodulation mode of the external radio. Only the basic modes that are common to both SpectraVue and the radio will be tracked.

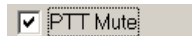

PTT Mute

If PTT Mute is selected then SpectraVue attempts to track the PTT state of some transceivers and mute the soundcard during transmit of the external radio.

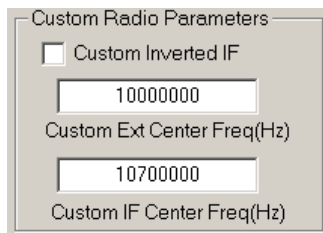

Custom Radio Parameters  
 Custom Inverted IF  
10000000  
Custom Ext Center Freq(Hz)  
10700000  
Custom IF Center Freq(Hz)

If the “Custom” radio is selected then an external radio that does not have frequency controlling capability such as a homebrew radio or fixed frequency down converter can be setup using these Custom parameters. The IF center frequency and associated input frequency and inverted spectrum status can be set.

### 3.1.6. General Setup

The General Setup Menu is a “catch all” menu for a variety of program settings.

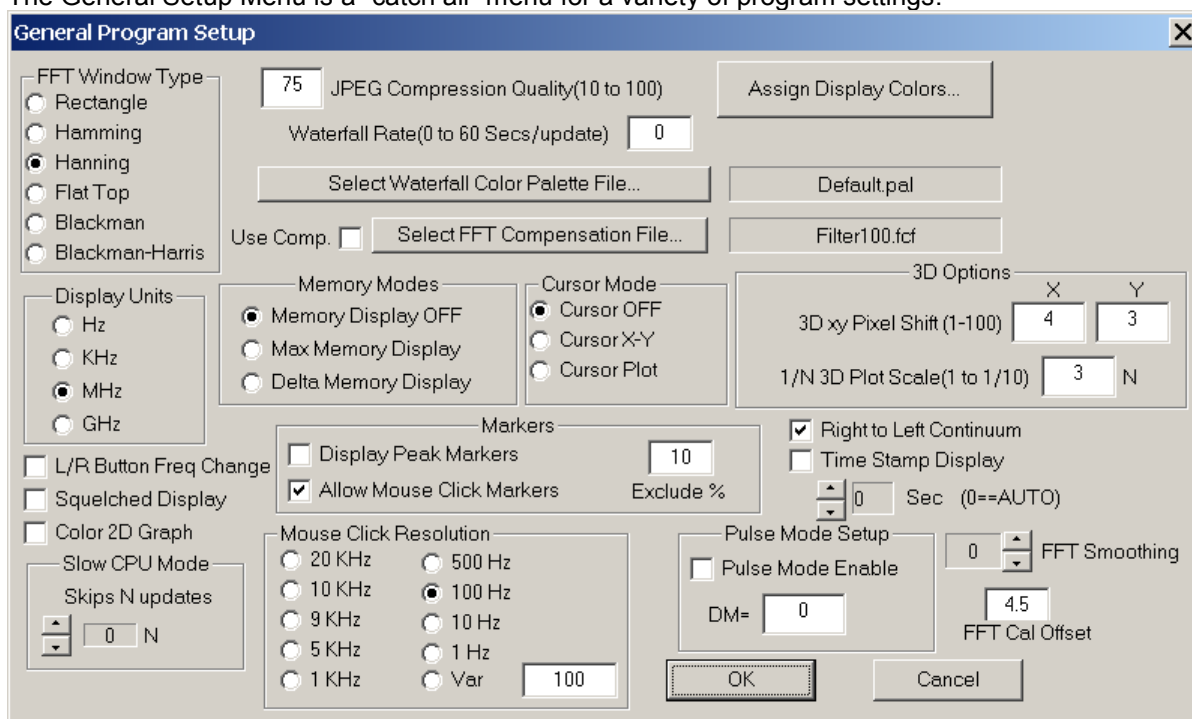

#### FFT Window Type

The FFT window type can be selected. Each of these windowing functions have different characteristics trading off frequency resolution and amplitude accuracy. The Hanning window is a good all around window to use.

#### Display Units

The display units that are used for the display and frequency controls can be specified.

#### L/R Button Freq Change

This checkbox selects between two methods of using the mouse buttons to change the frequency controls. When checked, the left mouse button increases the frequency and the right button decreases the frequency of the selected digit.

If the box is NOT checked, then the digit frequency is increased by left clicking on the top part of the digit and decreased by left clicking on the bottom part of the digit.

#### Squelched Display

This enables a mode where the display is only updated when the squelch is open when using the demodulation modes. Not only is the display “frozen” when the squelch closes but any FFT data file such as the .bmp capture or binary data file is not written into when the squelch is closed. Any wave file being written into is unaffected by this setting since they have an independent control for qualifying with the squelch control.

#### Color 2D Graph

Selecting this feature changes the 2D FFT display mode so that the graticule is replaced by a graduated color scheme where the 2D display changes color with amplitude using the same palette as the waterfall display.

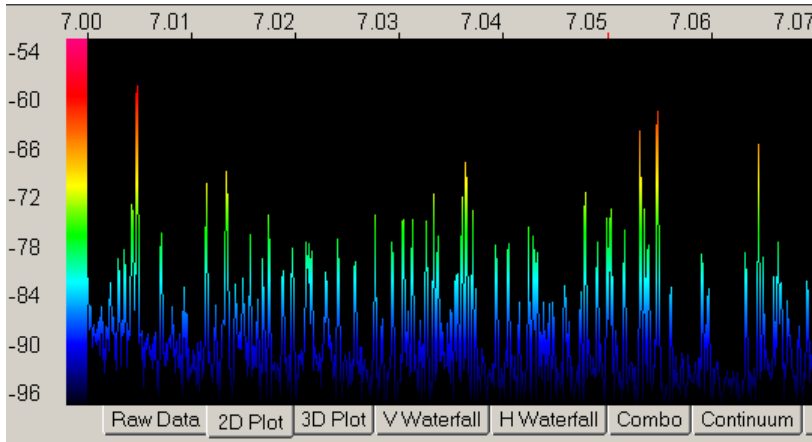

### Slow CPU Mode

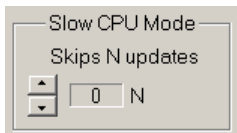

The Slow CPU mode forces the program to skip display updates in order to reduce computational load on the processor. As the number of N grows larger, the more updates that are skipped by the display. A value of zero runs the display at full speed.

### Mouse Click Resolution

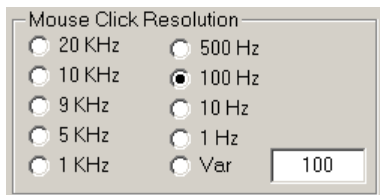

This group of menu items allows the selection of how to round off the frequency when using the mouse to click close to a signal on the display.

### JPEG Compression Quality

The image quality of the .jpg compression can be adjusted. One trades off quality for smaller files. The larger the number, the larger the file and better the quality. .PNG files are best used for all images except waterfalls. The 2D graphs compress very well with .PNG and there is no image quality loss.

### Waterfall Rate

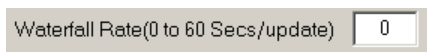

The Display update rate edit box can be used to cause the display rate to be very slow to allow long waterfall or continuum captures. The value is from 0 to 60 seconds between updates in 1-second steps.

### Assign Display Colors

A submenu allows for changing various display item colors.

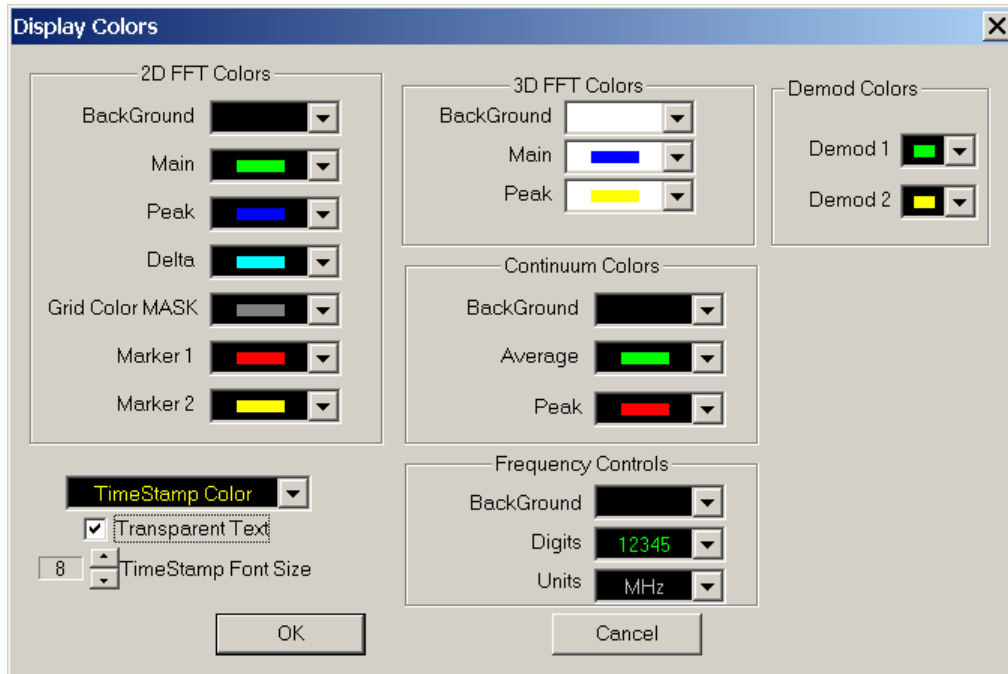

### Select Waterfall Color Palette File

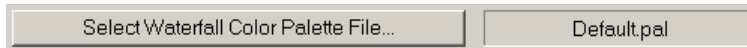

A submenu allows one to pick a different waterfall palette file for use with the waterfall displays. \*.pal files are used that are text files that contain a table with 256 rows representing power (1st row highest power). Each row contains an R,G,B value each with a range of 0-255 separated by a space.

Example format for a couple of rows:

```
25 255 171
41 232 0
```

.....

### Select FFT Compensation File

A submenu allows one to pick a FFT compensation file. A special file can be invoked to flatten out the filter responses of some of the SDR-xx IF filters. This is useful when doing extremely weak signal analysis and removes the ripple from the filter pass band.

These files have an extension of .fcb and a name corresponding to the AD6620 filter bandwidth that it will compensate.

For example the file "Filter1500.fcb" is used to compensate the 1500KHz BW AD6620 filter setting.

Before:

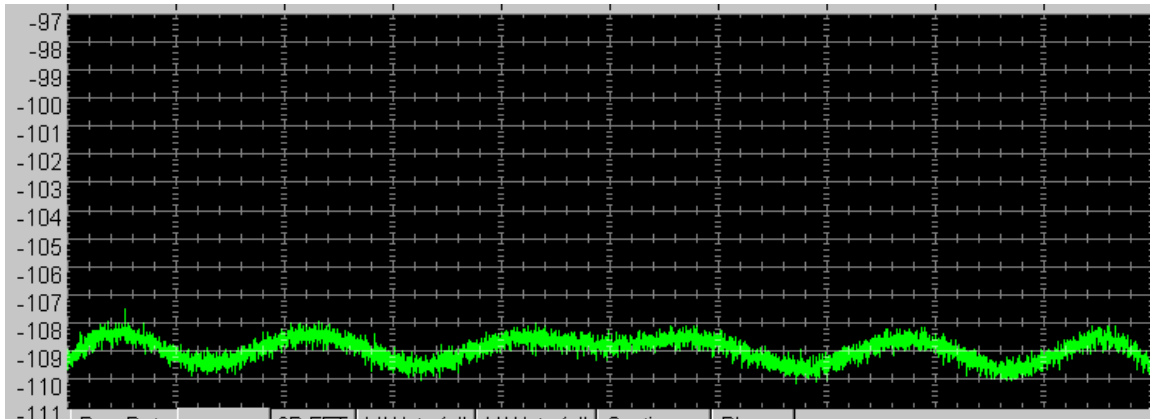

After:

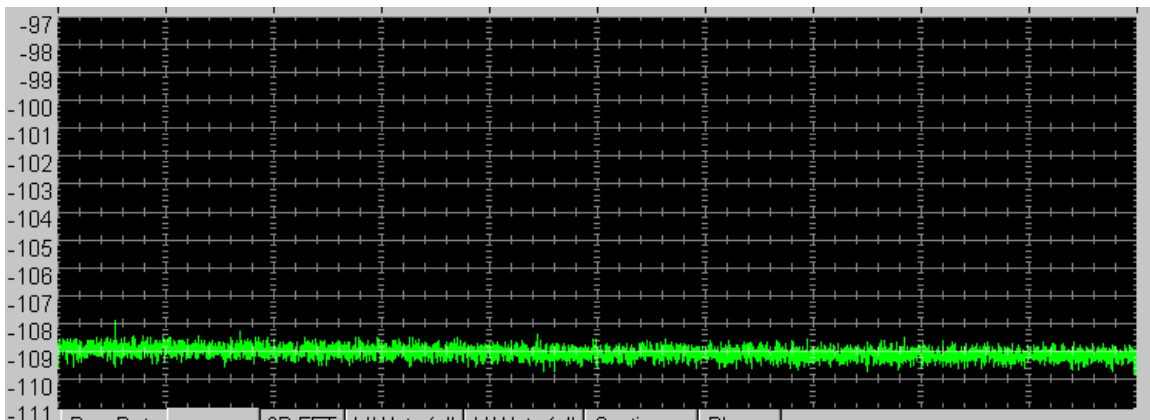

## Memory Modes

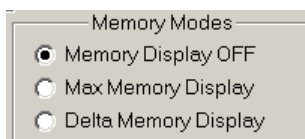

Three radio buttons are used to select the memory modes.

The max hold mode adds a second trace on the displays that is the maximum value for each point in the display over time. Pressing the "Clr Max FFT" button on the main screen above the "info" box will reset the maximum values.

The delta display mode allows the user to save the current displayed trace into memory and then display a second trace which is the difference between the stored trace and the current FFT trace.

Pressing the "MEM=FFT" button will save the current fft trace to memory.

Pressing the "AUTO delta" button toggles between the delta display (difference between current and stored) and the current and the stored memory traces. All three are displayed on the screen with different colors to distinguish them. The stored memory trace uses the Peak trace color.

## Cursor Modes

The Cursor Mode selections allow the user to select either no mouse cursors, an X-Y cursor, or a Plot Cursor.

The cursors are not available in the raw data or phase display.

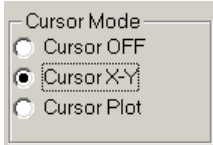

The X-Y mode shows the frequency and amplitude of the cursor mouse position on the screen.

The Plot mode shows the frequency of the mouse position on the screen and the amplitude of the plot data at that frequency position on the screen. Leaving the cursor hovering at that position will update automatically as the data of the plot changes.

If the cursor is in a waterfall display only the frequency is shown.



If the Cursor Mode is Off, then the cursor information of the plot is shown in text just to the left of the main frequency control.

### Markers

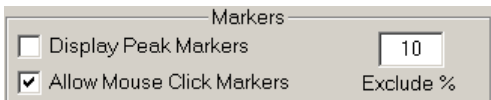

**Display Peak Markers** - This box enables a peak finding routine that shows the 4 highest power peaks as O's on the display as well as numeric values in the upper left of the 2D display screen.

There are 4 peak markers with 4 different colors. The text display is sorted from highest to lowest amplitude.

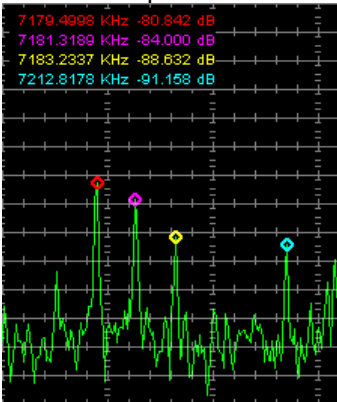

This is a more accurate way of obtaining frequency and amplitude since the actual FFT value is used and not the screen accuracy

The "Exclude %" box allows the user to exclude a specified percentage of the total screen width around a previously found peak. This keeps from finding all the peaks around a single "jagged" signal.

**Allow Mouse Click Markers** - This box enables the display marker system that works in the following way:

1. Right click on the spectral display near where you want to attach a marker. A red triangle should attach to the FFT display. The F3 to F8 keys can be used to position it exactly where you want. F3, 4, and 5 move it left while F6, 7, and 8 move it right at different rates. The numeric value of the marker is shown in the upper left of the 2D display screen.

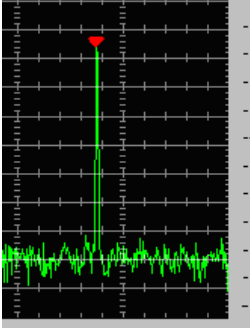

2. Left click on another part of the waveform and the first red marker freezes at the last value of the spectrum and a new yellow marker attaches to the new FFT position. It can also be moved with the function keys. The numeric value of the delta between the two markers is now shown in the upper left of the 2D display screen.

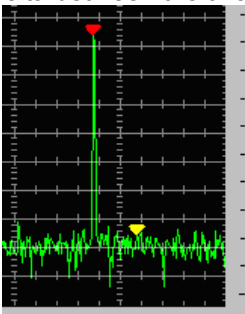

3. Right clicking again gets back to step 1. Right click again and the markers are turned off.

### 3D Display Parameters

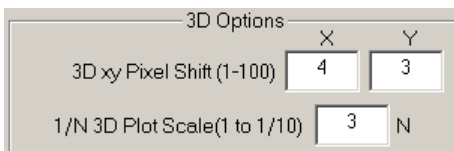

The 3D xy pixel shift edit boxes allow the user to specify how many screen pixels the 3D display will move every capture. The screen moves left and up.

The 3D scale value allows the user to scale the individual FFT amplitudes within the 3D display.

### Right to Left Continuum

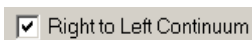

The Right to Left Continuum allows changing the direction of the continuum scrolling.

### Time Stamp Display

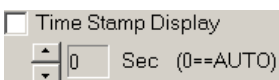

The Timestamp Display box enables time stamping of the waterfall and continuum displays. Adjust the color, size, and transparency of the timestamp font to give best viewing using the "Assign display Colors.." menu.

The Spin control allows the user to specify the time in seconds between each timestamp or by setting the value to zero will automatically calculate a suitable update rate.



## FFT Max dB

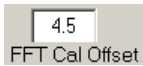

This edit box allows entering a value to calibrate the display read directly in dBm. This value is added to the FFT values. It typically is around 4dB for the direct input mode.

## Pulse Mode Setup

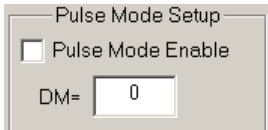

This check box changes the operation of Spectravue from frequency domain display to time domain display. This mode will be implemented and expanded in future versions of SpectraVue. It was originally implemented as a special mode to observe pulsars but may be expanded to other applications where power versus time is more useful than power versus frequency.

The FFT size becomes the capture buffer size and the main frequency control toggles between SDR-xx center frequency and a time position control. The Span control now is in time units instead of frequency.

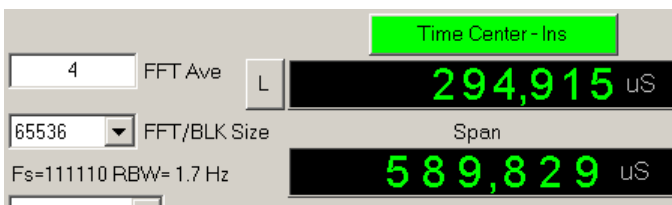

This mode is not useful at the present time with the current hardware/firmware due to the lack of triggering capability on the current SDR-xx hardware and firmware versions. Later releases may incorporate triggering to utilize this mode.

### 3.1.7.Help

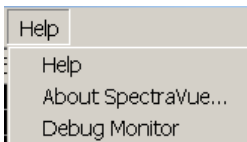

Program help is this .pdf format file.

About SpectraVue brings up program and SDR-xx version information.

Debug Monitor brings up a

## 3.2. Plot Area

### 3.2.1.Raw Data

This view is of the raw input data versus time. Its purpose is to give the user a quick look at incoming data to verify its general amplitude. There are no user controls to this display. The amplitude is automatically scaled to fit the screen and the time axis is not calibrated but is a function of the sample rate and screen resolution.

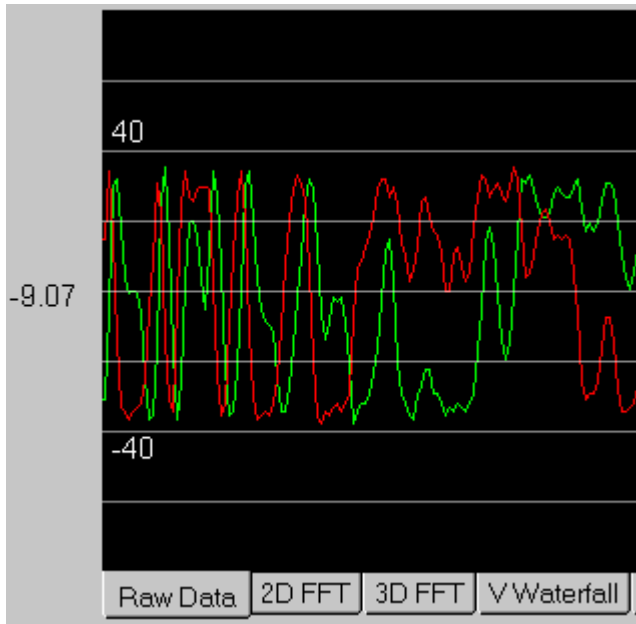

If it is real data then there is only one trace. Complex data is displayed as two different traces with different colors. The two numbers in the display area are the max and min values of the incoming signal. The range of inputs is a 16-bit value or 0 to +/- 32767.

The DC offset is displayed to the left of the screen. This may be of use for adjusting the soundcard DC offset input parameters.

### 3.2.2. 2D Plot

The 2D FFT display shows the spectrum amplitude versus frequency plot of the incoming signal. The center frequency and frequency span are set by the two main controls just below the FFT display area. Amplitude in dB referenced to full scale is displayed on the left side of the display and frequency along the top. The slider control on the right can be used to shift the amplitude display up or down.

FFT amplitude power is in dB referenced to full scale (a single sine wave with an amplitude of +/-32767 or 16 bits). This can be calibrated to dBm by entering a dB offset in the General Setup menu.

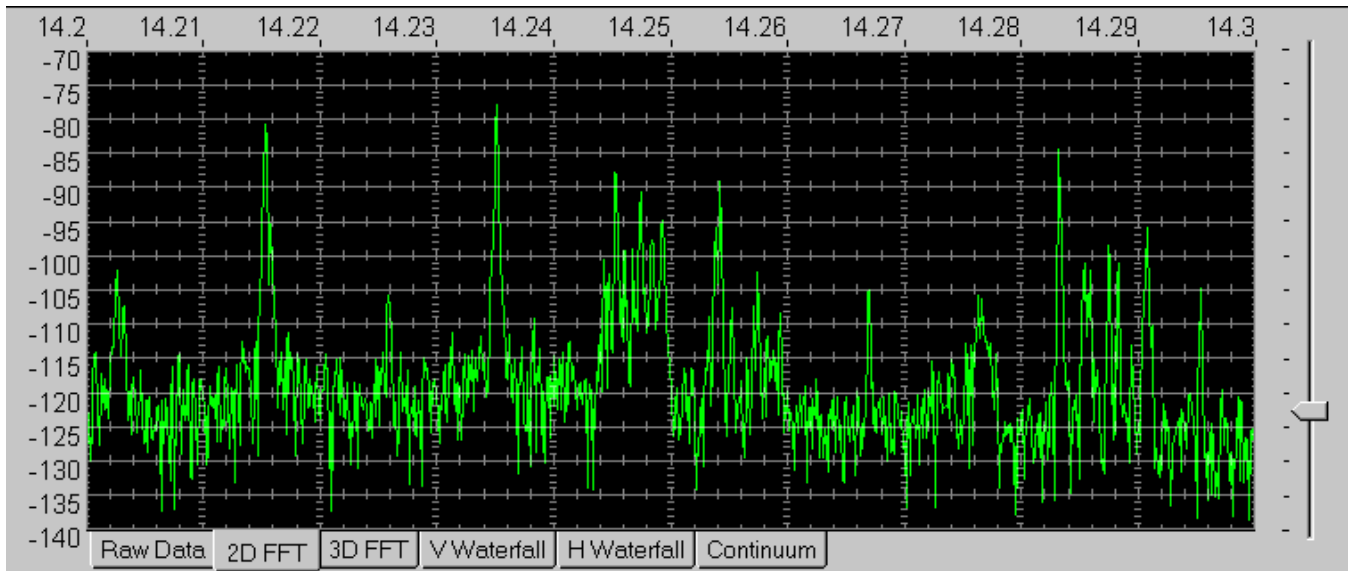

An alternative 2D view is available by choosing the "Color 2D Graph" selection in the General Setup Menu. This view adds color to the display in place of the internal scale markings. The colors correspond to the Waterfall color palette.

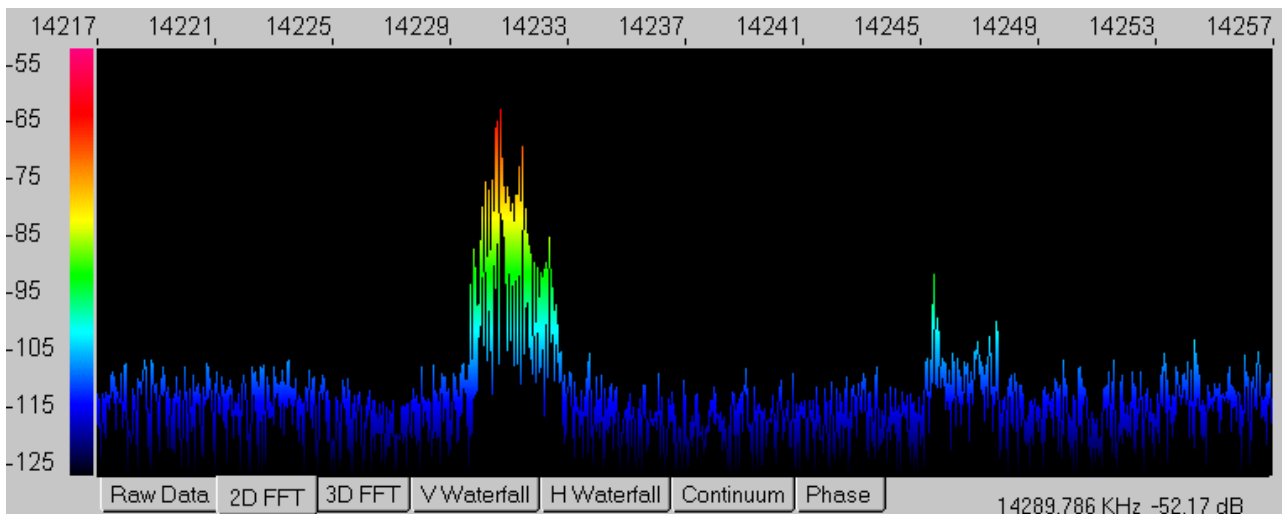

### 3.2.3. 3D Plot

The 3D FFT display shows the spectrum amplitude versus frequency plot of the incoming signal and then provides a running history in time of the FFT plot by shifting each past display up and to the right. The center frequency and frequency span are set by the two main controls just below the FFT display area. Amplitude in dB referenced to full scale is displayed on the left side of the display and frequency along the top. The slider control on the right can be used to shift the amplitude display up or down. For better displays, play with the amplitude offset bar on the right and also the FFT smoothing value as well as other 3D display options located in the General Setup Menu.

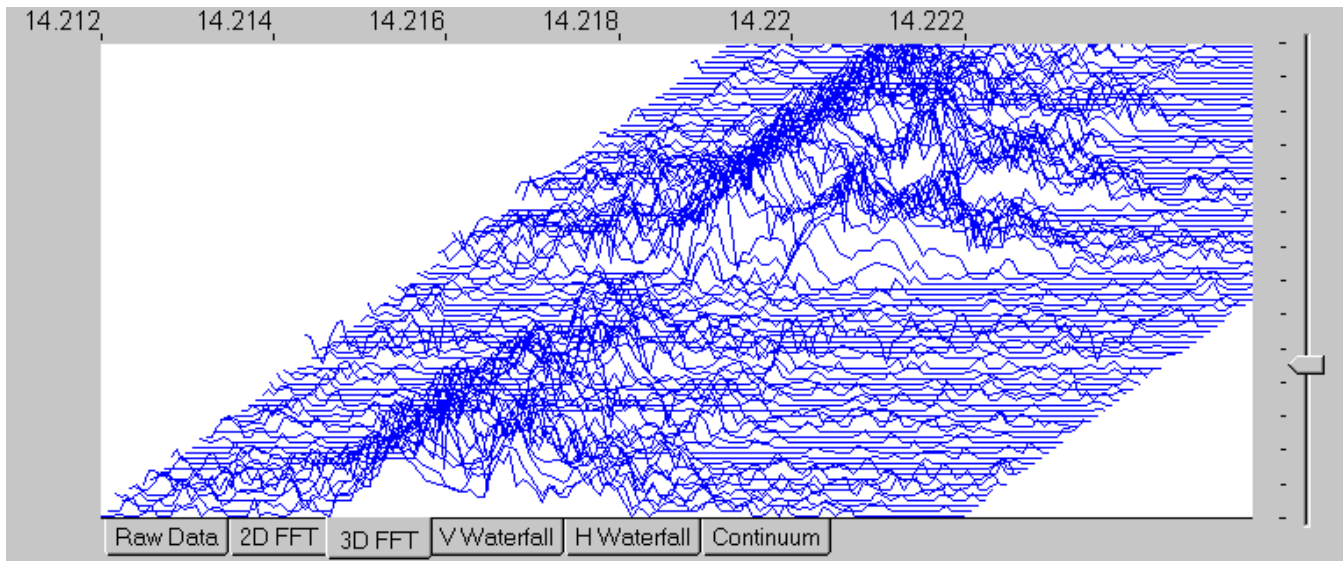

### 3.2.4.V Waterfall

The vertical waterfall FFT display shows the spectrum amplitude as a color instead of as a height on the display. Frequency is the horizontal axis and time is the vertical axis. The center frequency and frequency span are set by the two main controls just below the FFT display area. Amplitude in dB referenced to full scale is displayed on the left side as a color scale. The slider control on the right can be used to shift the amplitude display up or down in large increments and the spin control on the lower left side of the display can be used to make small shifts in the color amplitude map. An optional timestamp feature can be invoked (from the General Setup Menu) to mark the UTC time as the display scrolls down.

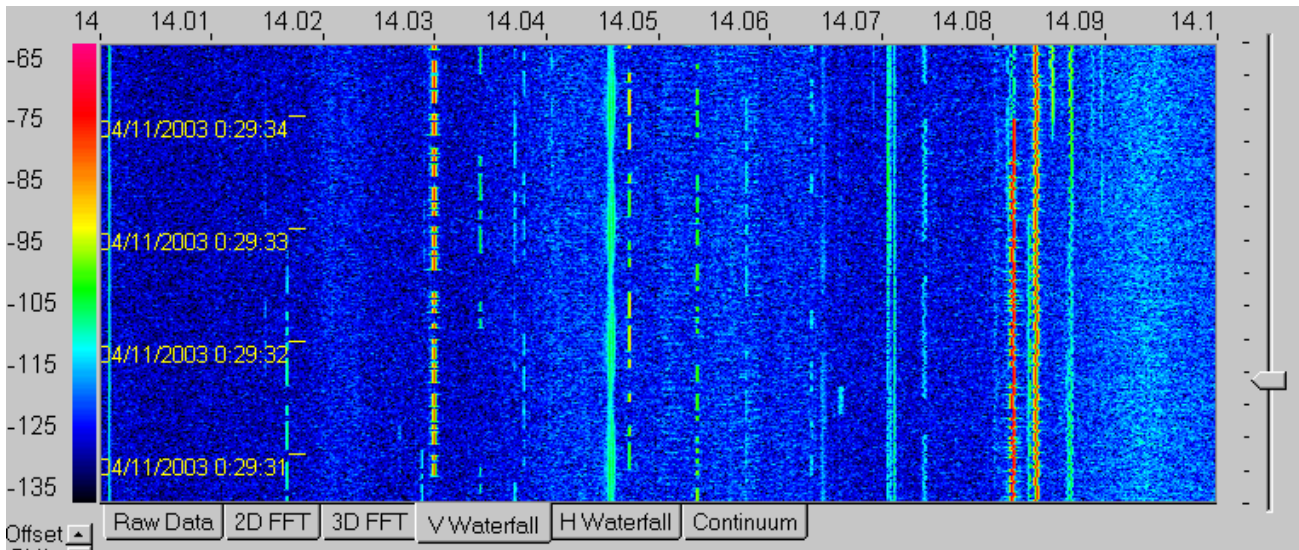

### 3.2.5.H Waterfall

The horizontal waterfall FFT display shows the spectrum amplitude as a color instead of as a height on the display. Frequency is the vertical axis and time is the horizontal axis. The center frequency and frequency span are set by the two main controls just below the FFT display area. Amplitude in dB referenced to full scale is displayed on the topside as a color scale. The slider control on the right can be used to shift the amplitude display up or down in large increments. An optional timestamp feature can be invoked (from the General Setup Menu) to mark the UTC time as the display scrolls left.

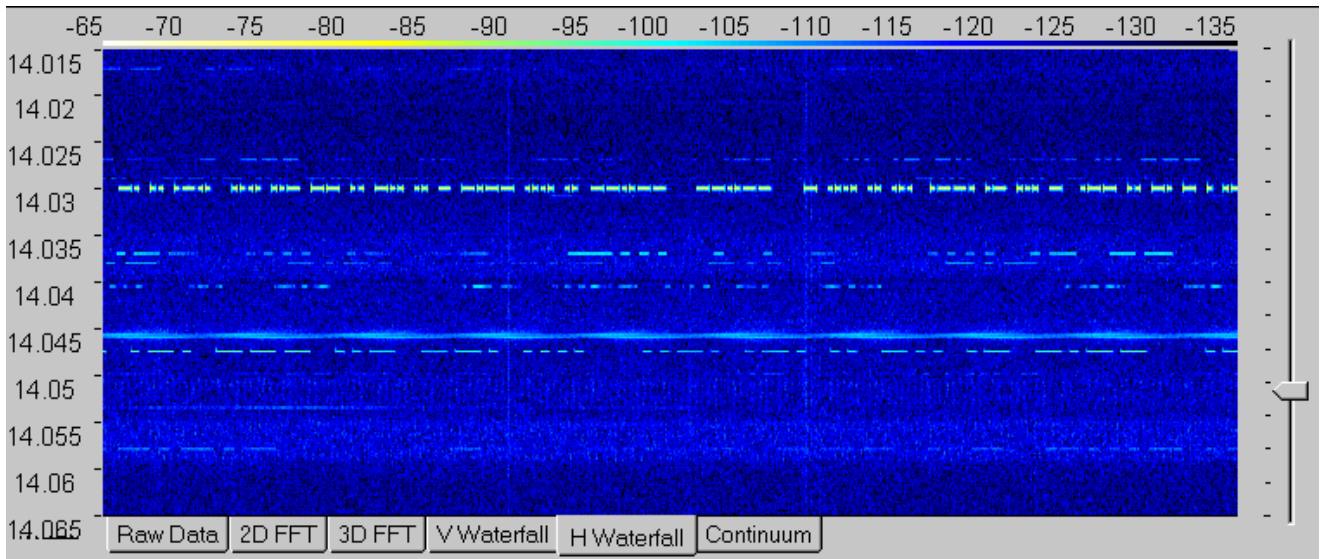

### 3.2.6.Combo

This view combines the 2D FFT view with the vertical waterfall view.

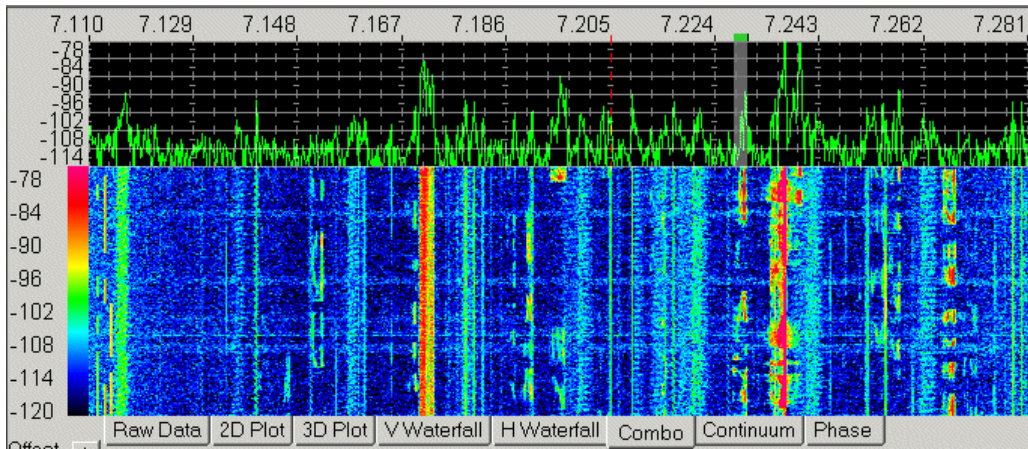

### 3.2.7. Continuum

The continuum display mode displays the total power over the entire frequency span versus time. An optional secondary trace can be displayed that also shows the peak power within the same span versus time. This is invoked from the General setup menu by selecting the Enable Peaks check box. Time stamping and Cursor Markers can also be enabled (from the General Setup Menu) for this scrolling display.

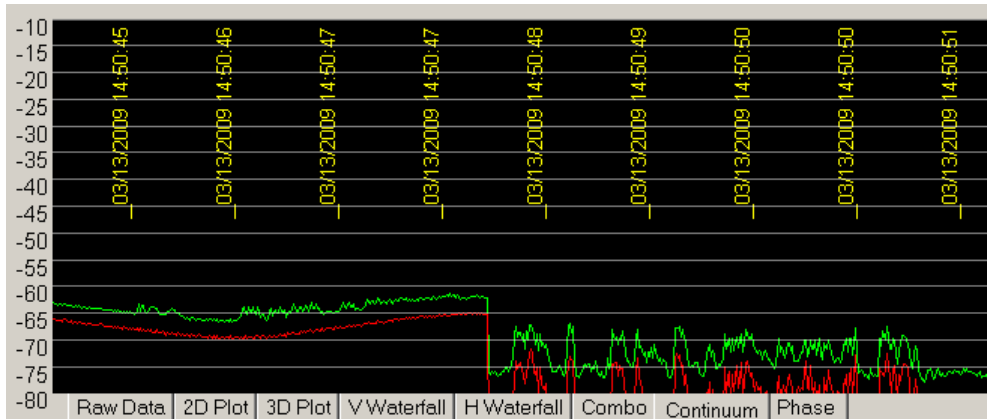

FFT amplitude power is in dB referenced to full scale (a single sine wave with an amplitude of +/-32767 or 16 bits). This can be calibrated to say dBm by entering a dB offset in the FFT Setup menu.

### 3.2.8. Phase

The Phase display mode displays the I and Q data points in an x-y axis plot. 512 points are plotted at a time. The signal strength must be fairly strong to give interesting results and also as narrow a bandwidth so multiple signals don't confuse the display. It is not phase locked so will rotate unless manually stabilized.

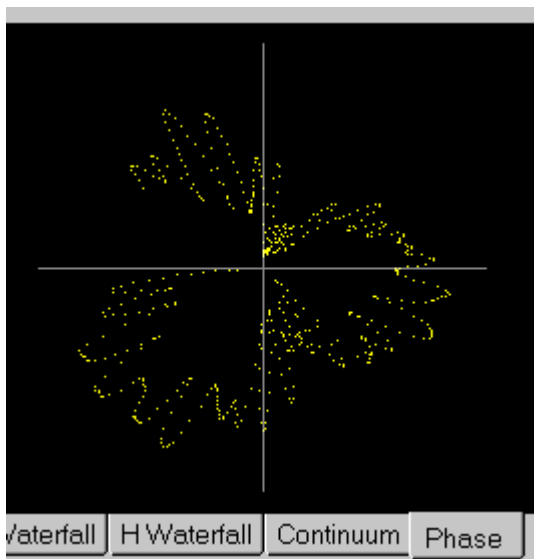

### 3.3. FFT Controls

#### 3.3.1. FFT Ave

The FFT average control is used to specify an averaging function that is applied to the FFTs. This is a point by point running average up until the number of samples reaches the specified average limit then it becomes a low pass filter with a time constant approximately equal to the averaging value.



This function is useful in averaging out noise and allowing a signal to be more easily viewed in a noisy background. The down side is that fast moving signals will become blurred. The current average sample count is displayed in the Status Bar at the bottom of the screen so one can monitor the progress of long averages.

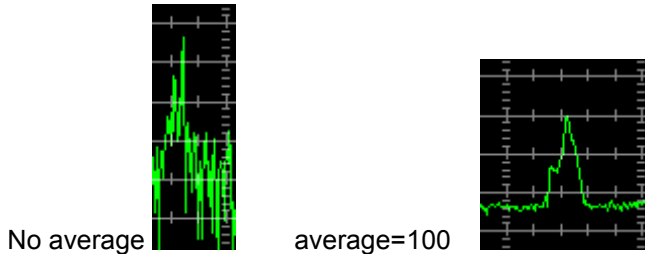

#### 3.3.2. FFT/BLK Size



The FFT size pull down selection control is used to select the size of the FFT. The range is from 2048 to 262144 points. The larger the FFT the better the frequency resolution but the longer it will take to process since more data points are required between updates.

#### 3.3.3. FFT Information

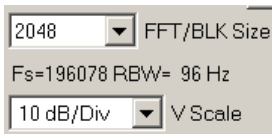

Basic information of the current FFT settings are shown on the lower left side of the main screen. Fs is the current sample frequency and RBW is the FFT resolution bandwidth (ie the smallest frequency resolution of the FFT display).

#### 3.3.4. V Scale



The Vertical scale control allows the selection of dB per division for the FFT amplitude. The range is from .2dB/Div to 10dB/Div. The display will only show 14 divisions at a time so the slider control on the right side of the display can be used to change the viewable range of amplitudes.

#### 3.3.5. Auto Scale Button

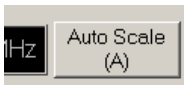

This button can be used to perform an automatic centering of the signal within the display area. It performs an average of all the FFT points and adjusts the vertical position so that the average is somewhere near the bottom of the screen. This function is automatically invoked whenever the vertical resolution is changed. This control is particularly useful in finding the display trace if it is off screen. It can also be invoked by pressing the 'A' key on the keyboard.

This button can change functions when in the different screen MEMORY modes that are discussed in the General Setup Menu section.

### 3.3.6. Manual Vertical Slider Control

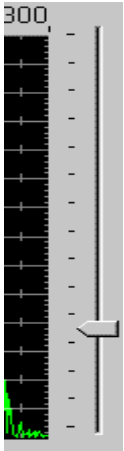

This control is used to move the viewable vertical window of the display. The control can be changed by dragging the control arrow or by clicking on either side of the arrow. The total range of the display is -170 to 170 dB referenced to full scale.

### 3.3.7. NCO Null

The NCO Null button can be used to reduce the small spur that appears in the center of the screen due to DC imbalances in the I and Q signals. Normally atmospheric noise will mask this spur but when performing measurements where the noise floor is very low, this spur can be dominant.

Pressing this button initiates an auto notching procedure that will attempt to remove the DC offsets on the I and Q digital signals. It takes about 10 seconds to complete. One must make sure there are no real signals present when performing this calibration so it is best to have the antenna disconnected.

The center NCO spur is frequency dependent so the procedure must be done whenever the center frequency is changed significantly.

### 3.3.8. Smoothing

This control is located in the General Setup Menu not on the main screen.

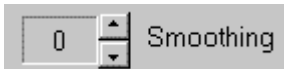

The smoothing function averages FFT bins within the same sample data block. This function is useful for wide bandwidth signals such as GPS and smoothes the overall shape of a wide signal.

(Note: this is very CPU intensive so can slow down things if large values are used)



No smoothing

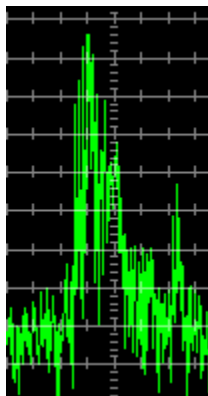

Smoothing = 6

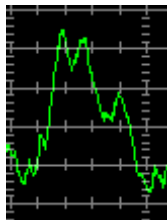

### 3.4. Frequency Controls

#### 3.4.1. Main Frequency Control

A screenshot of a digital display showing the frequency 146.520000 MHz. The digits are green on a black background.

The center frequency control is used to specify the display center frequency. This value and the frequency span value determine the FFT display's range and position within the FFT. If the SDR-xx is used as an input source, this frequency is also the NCO frequency that corresponds to the zero frequency of the complex FFT. The frequency units can be specified in the General Setup menu.

The frequency control can be set in several ways.

Place the mouse cursor on the digit you wish to change or press one of the arrow keys. The digit background will change color. Use the mouse or left or right arrow keys to change digit positions within the control.

A screenshot of the same digital display showing 146.520000 MHz. The second zero from the right (the digit '0' in '000') is highlighted with a yellow background.

- Type the desired numeric digit using the keyboard. The selected digit will move to the right so that an entire frequency value can simply be entered from the keyboard.
- Click the mouse on the top of the selected digit to increment that digit value or on the bottom of the digit to decrement it. (This mode selected in "General Setup" Menu)
- Use Left and Right mouse buttons to inc/dec digit. (This mode selected in "General Setup" Menu)
- Use the mouse scroll wheel to increment/decrement the digit value.
- Use the up or down arrows to increment or decrement that digit value and zero all following digits.
- Use the Page Up or Page Down keys to increment or decrement just the selected digit and not the entire frequency value. (digit value does not roll over to adjacent digits)
- Click the left mouse button within the display area on the frequency you wish to center.
- If the mouse cursor is in the display area then the mouse scroll wheel will increment or decrement the frequency in step sizes specified in the General Setup Menu.
- A USB "Power Mate" knob from Griffin Technologies can be mapped to the following keys:  
<http://www.griffintechnology.com/>
  - CTRL-F1 = digit decrement (Rotate Left)
  - CTRL-F2 = digit increment (Rotate-Right)
  - CTRL-F3 = move digit position left (Push and Rotate Left)
  - CTRL-F4 = move digit position right (Push and Rotate Right)
  - CTRL-F5 = Toggle frequency control between center and demod function. (Actually a "double-click" operation is required.)



The Center frequency control has a dual function when running the program in the demodulation, HF Tracking, or Pulse mode. This button sets the function of the control to either the normal center frequency control or it can be used to set the demodulation center frequency which can be anywhere within the display frequency span. This button is only active if in the demodulation, HF Tracking, or Pulse mode.

When in Center Frequency mode, clicking on a position of the screen will make that position the new center frequency.

When in the Demo mode, clicking on a position of the screen will make that position the new demodulator frequency and keep the center frequency fixed.

When operating with an external radio in the HF Tracking mode, this button also selects the external radio frequency.

### 3.4.2.Span Frequency Control

The span frequency sets the range of frequencies that will be displayed on the screen. The display will always show frequencies from Center - Span/2 to Center + Span/2. The control operates exactly as the center frequency control except the arrow keys do not automatically invoke the control like the main frequency control.



### 3.4.3.Frequency Lock Button

The small button just to the left of the main frequency control can be pressed to lock the frequency display. The button will turn red indicating a locked condition.



Pressing it again will unlock the frequency display.

This is useful to keep from accidentally moving off frequency.

During wav file recording, the control will display an 'R' indicating the frequency cannot be changed while recording.



### 3.5. Start/Stop/Pause/Cont Controls

Three buttons at the bottom of the screen control the starting, stopping, pausing, or resuming of the data capture process. Function keys F10, F11, and F12 are mapped to these buttons as well.

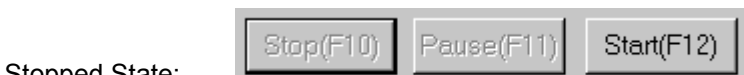

Stopped State:

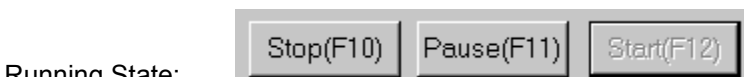

Running State:

Paused State:



### **3.6. Sound Card Audio Controls**

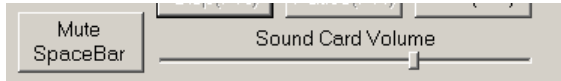

The Mute button can be used to mute the audio from the soundcard. The Sound Card Volume control is used to adjust the audio level from the sound card. These are mapped to your PC soundcard mixer controls and will mimic whatever setting your PC mixer main controls are set to.

If you have more than one sound card, you will need to select the mixer and sound card you wish to use in the Output Setup Menu.

The Mute button can also be toggled by hitting the PC keyboard Spacebar. Pressing CTRL-Spacebar will un-mute the soundcard regardless of its toggled state.

### 3.7. Demodulation Controls

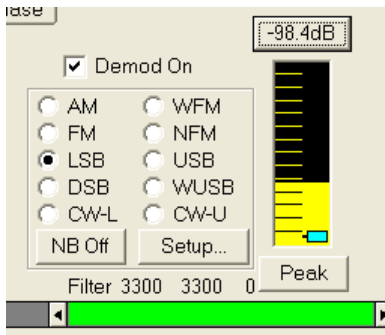

The “Demod On” checkbox enables or disables the demodulator section. It is only available when the SDR-xx bandwidth is within certain ranges.

The NB Button invokes a Noise blanker that is common to all demodulation modes and whose parameters can be adjusted in the “Setup” menus.

The group of selection buttons are used to pick the demodulation mode desired such as AM or USB etc.

For each mode, one can press the “Setup” button to adjust various parameters for the selected demodulation mode such as filter bandwidth, AGC, etc.

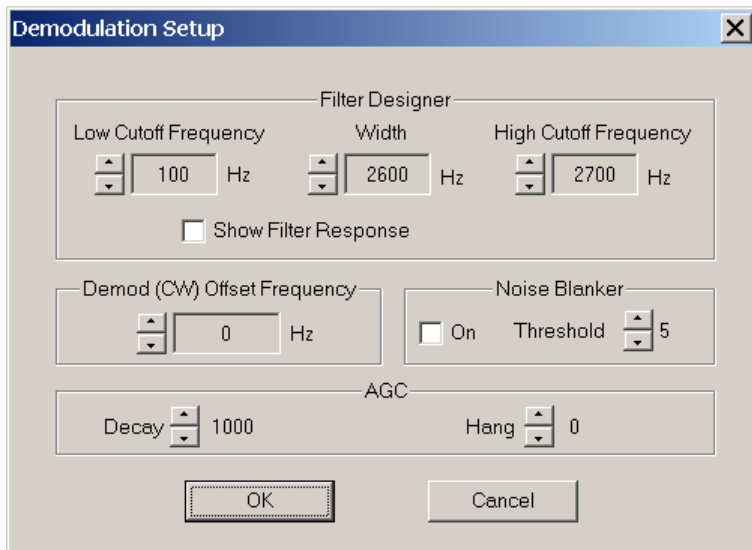

If the "Show Filter response" box is checked, then the actual filter shape is displayed on the 2D FFT display. The Hi and Low cutoffs are the -6dB points of the filters.

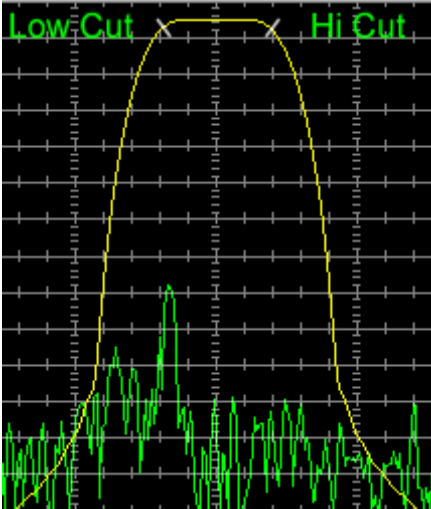

If the high cut off is greater than 3600Hz, then a higher sample rate is used in the filters. This causes a jump in the shape of filters about this transition point. The higher cutoff filters are not as sharp as the narrower ones.

A custom slider control below the demodulation mode section can be used to adjust the current demodulator filter settings by using the mouse to move the low cutoff, high cutoff, or move the entire filter with respect to the demodulation center frequency.

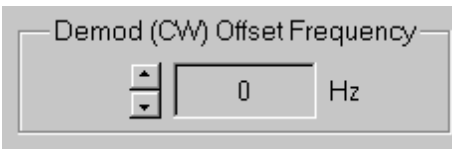

This edit box provides a way to offset the filter and display frequency for receiving CW tones. This is essentially the tone frequency that will be heard in the CW mode when the display frequency is exactly the same as the incoming signal.

This offset can also be used in the WUSB mode to shift the demodulated signal up in frequency before sending it out. This can be used to output a 12KHz IF signal to the sound card for further decoding by a DRM (Digital Radio Mondiale) decoder. If this offset value is >0 and is in the WUSB mode, then the demodulator frequency display changes to a center value so the incoming signal is centered as opposed to being at the left side as is normal for USB signals.

For DRM reception, set the offset to 7KHz and the low cut to 0Hz and the high cut to 10KHz. This will center the DRM signal around the 12KHz frequency going out the soundcard or wave file.

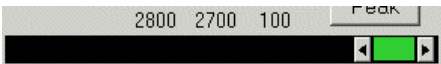

Clicking and dragging in the colored center section will shift the entire filter.

Clicking and dragging either the left or right arrow buttons will shift just the high or low cut off frequency.

The text above the slider represents the cut off frequencies and the overall filter width in the center.

+

### 3.8. Memory Controls

Clicking on the Memory Channels Button just to the right of the Span Frequency Control will pop up a menu with 20 memory channel buttons that can be independently programmed with center frequency and both demodulation channel parameters. This pop up menu can be dragged around your desktop to get it out of the way of the main screen.

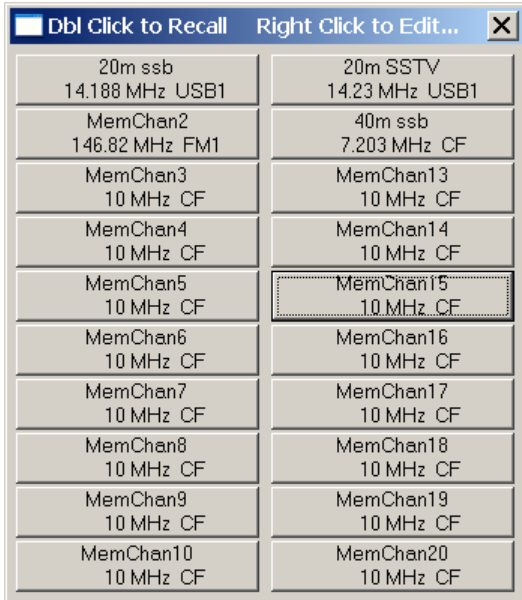

Memory channels are setup by first setting up SpectraVue's center frequencies and both demodulation channels to the desired settings. Then right click on the desired memory channel button to bring up the individual setup menu. Click on the "Clone Current Setting" button to load the memory channel with the current SpectraVue settings. One can also edit the channel text name that will be displayed on the memory channel button.

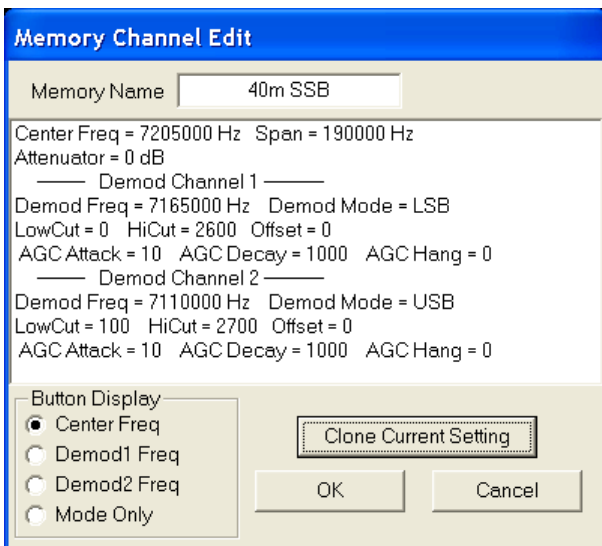

The Button Display group of selections allows the user to pick what type of frequency is displayed on the memory button. The Center Frequency(CF) or one of the demodulation channel frequencies. If demodulation frequency is chosen then the demodulation mode followed by a 1 or 2 denoting which demodulation channel is displayed after the frequency.

If the "Mode Only" selection is used, then only the demodulation mode and filter setups are saved not the frequencies or attenuator setting. This allows the user to setup custom modes and filter settings as a memory channel and not change the frequencies when the memory is activated. An example might be to setup a memory channel for DRM decoding.

To recall and activate a previously setup memory channel, just double left click on the desired channel button to load SpectraVue's center frequency, span frequency, and demodulation settings into SpectraVue's controls. Pressing the 'M' key will also pop up this menu. Pressing the 'Esc' key will remove the memory button menu.

**Note that other setup items such as FFT setup, SDR-xx settings, screen settings, are NOT saved in the memory channels so must be manually adjusted.**

The memory channel data is stored in the Spectravue.ini settings file upon program exit and automatically loaded when the program is invoked again. The .ini file can also be saved and loaded using different names using the "File" menu. This can allow essentially an infinite number of setups and memory channel groups to be created.

An example might be a separate .ini file for AM broadcast stations, another for the 20meter CW band, and maybe another for VHF channels when using an external IF radio such as the AR5000 tuned to the VHF band.

### 3.9. Status Bar

The bottom of the SpectraVue screen contains the current PC time in UTC format.

The left side of the bar shows various status information depending on the state of the program.

The example below shows the program running with an SDR-IQ as the signal source, the output is going to the PC soundcard, and 123 samples have been captured for FFT averaging.



SDR-IQ->Sound 123 | 9 Mar 2009 14:16:21 UTC

Another example shows the program waiting to begin recording while in timed recording mode.



Idle -Waiting to Record 23:59:40 Remaining- | 9 Mar 2009 14:21:59 UTC



## 4. Using With External Radios

Several radios can be used in conjunction with SpectraVue and the SDR-xx to extend the frequency range or for panadapter operation.

There are several modes of operation depending on the capabilities of the external radio. If the radio has an IF output within the frequency range of the SDR-xx and can be tuned using a serial port, then the frequency range can be extended where SpectraVue automatically tunes the external radio frequency (and vice versa).

If the radio can be tuned over a serial port but has no IF output, then the SDR-xx and the radio can track the same frequency using SpectraVue using the HF tracking mode.

Basically there are four modes of operation with external radios:

- HF Tracking, Keeping same center frequency.

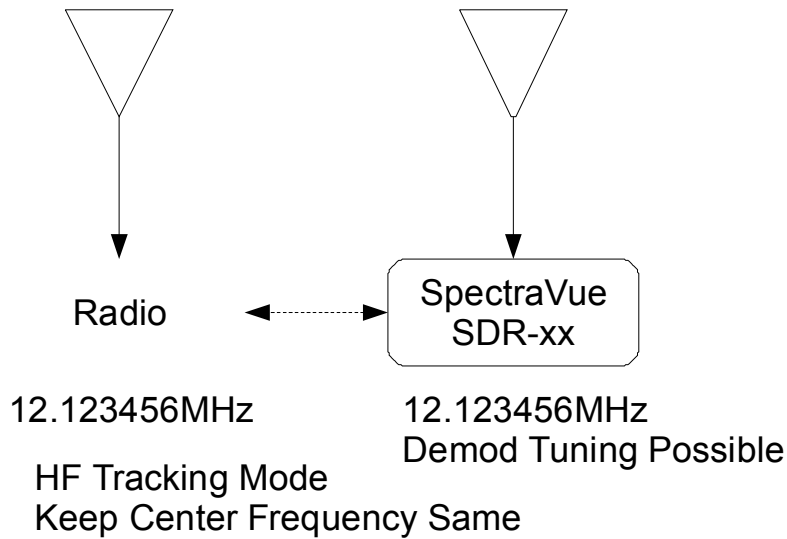

- HF Tracking, Allow independent tuning within HF band

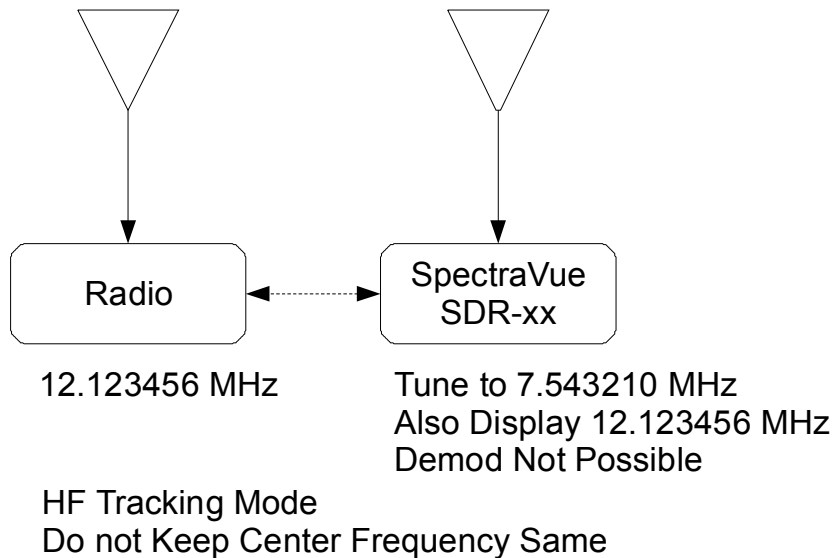

- IF mode(not HF Tracking), Keeping same center frequency  
This mode maintains the same center frequency on the radio as well as in SpectraVue. The demod can still be tuned within the bandwidth of the SDR-xx.

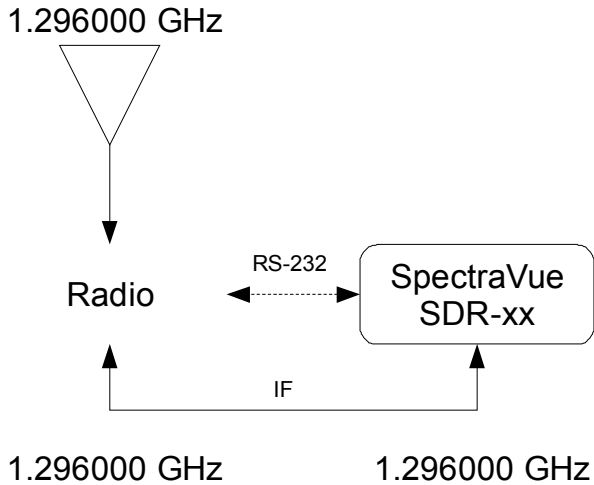

IF Tracking Mode  
Keep Center Frequency Same

- IF mode(not HF Tracking), Allow independent tuning within the IF bandwidth.

This mode could be used to monitor two signals at the same time as long as they both are within the IF bandwidth of the receiver.

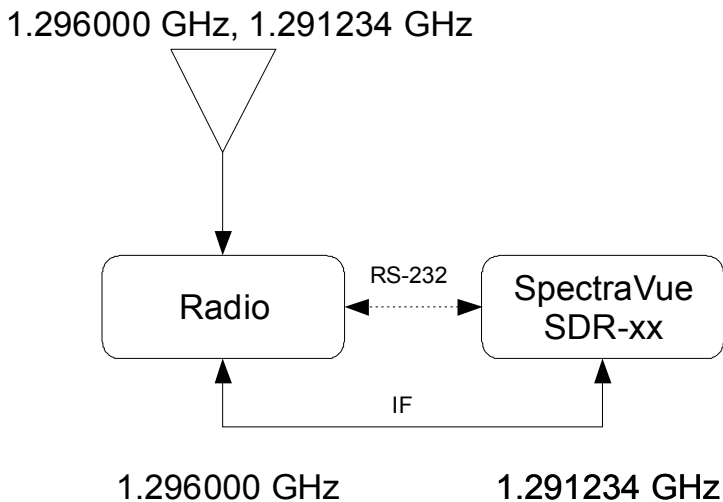

IF Tracking Mode  
Do not Keep Center Frequency Same

#### 4.1. AOR AR5000

The following block diagram shows the basic setup for using the AOR AR5000 receiver with the SDR-xx and SpectraVue. If the SDR-14 is used, then the PC's serial port must be used, otherwise the SDR-xx's RS232 port can be used to control the radio from SpectraVue.

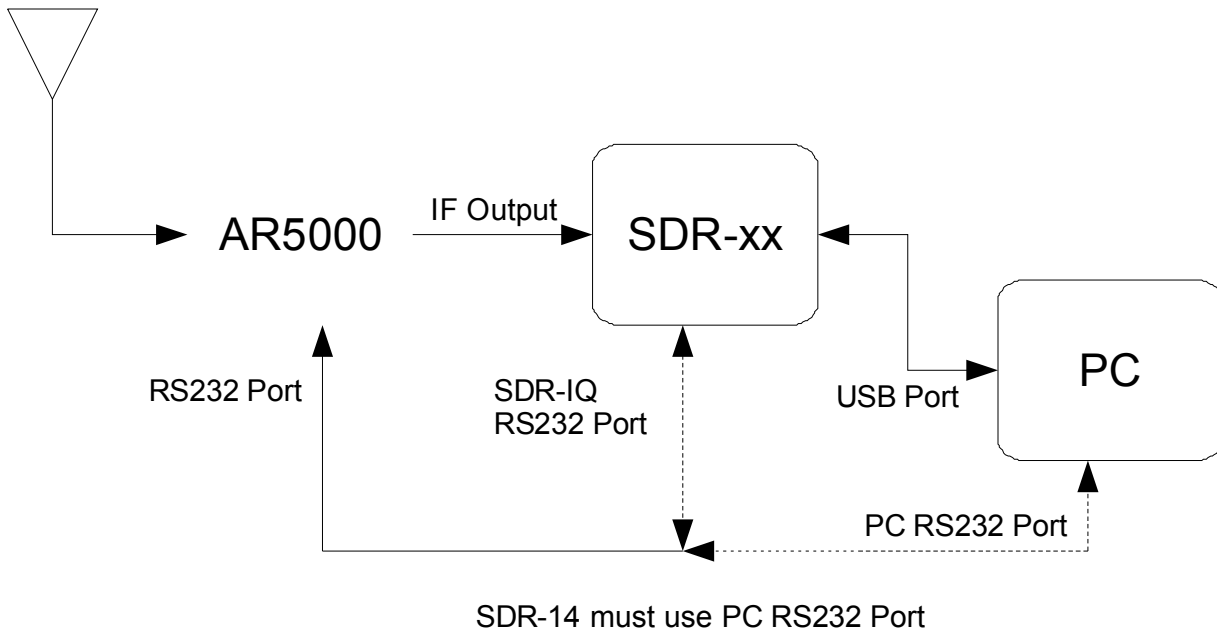

#### 4.2. Elecraft K3

The following block diagram shows the basic setup for using the Elecraft K3 radio with the SDR-xx and SpectraVue. If the SDR-14 is used, then the PC's serial port must be used, otherwise the SDR-xx's RS232 port can be used to control the radio from SpectraVue.

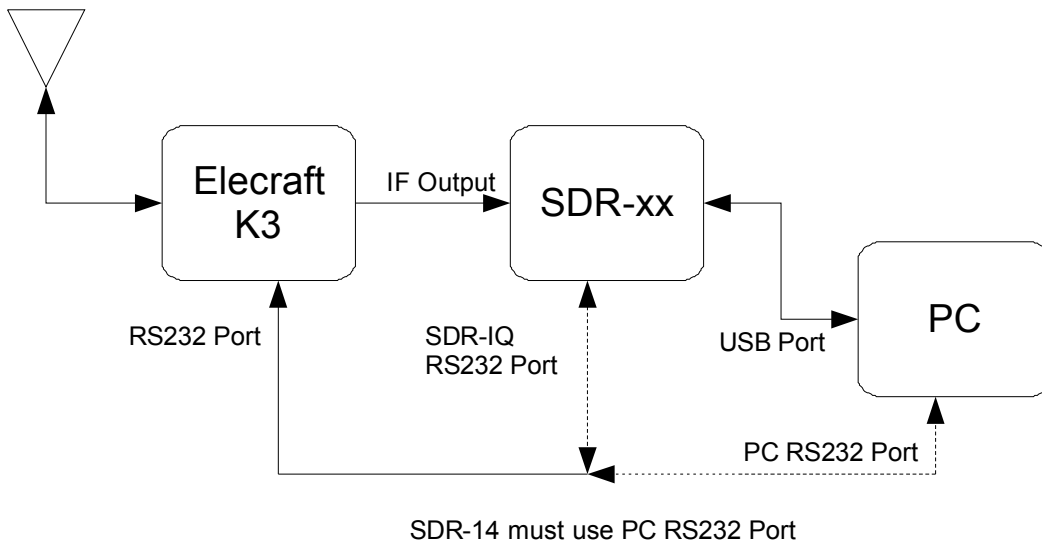

#### 4.3. Yaesu FT-1000MP

The following block diagram shows the basic setup for using the FT-1000MP radio with the SDR-xx and SpectraVue. If the SDR-14 is used, then the PC's serial port must be used, otherwise the SDR-xx's RS232 port can be used to control the radio from SpectraVue. There is no IF output on this radio so only the HF Tracking mode is supported.

***User must also add some sort of signal splitter and/or T/R relay when using the transceiver so as not to transmit RF power into the SDR-xx.***

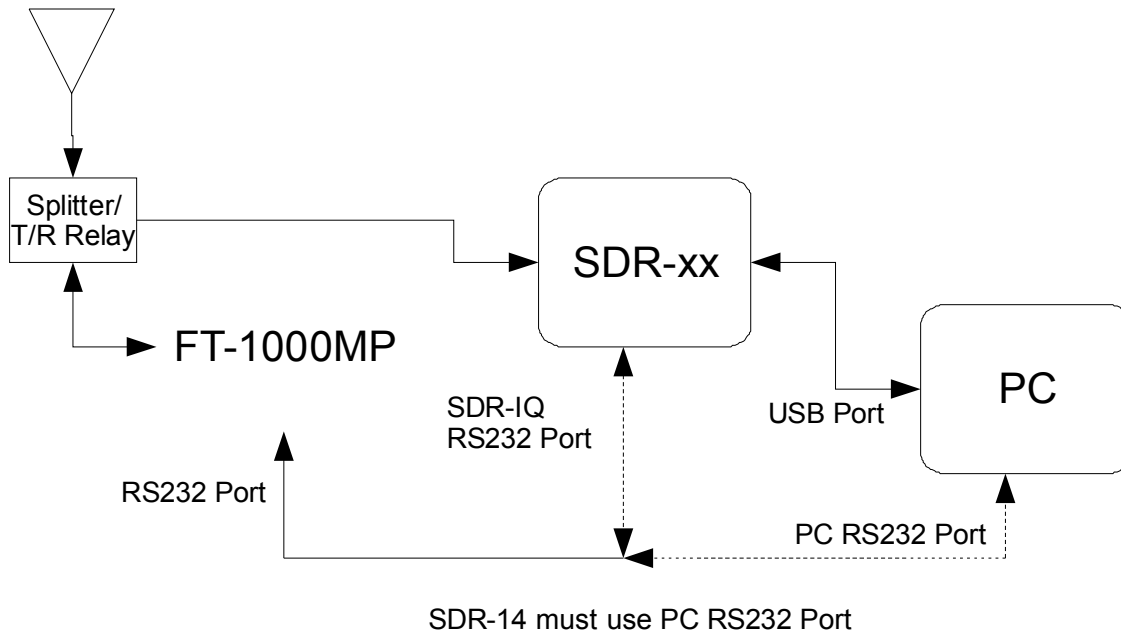

#### 4.4. Yaesu FT-2000(with IF-2000 module)

The following block diagram shows the basic setup for using the FT-2000 receiver with the SDR-xx and SpectraVue. The RFSpace IF-2000 interface board is required to be installed in the FT-2000 receiver. This board converts the 69.4515MHz IF of the FT-2000 to 10.5485Mhz that can be received by the SDR-xx. (80.0MHz LO)

If the SDR-14 is used, then the PC's serial port must be used, otherwise the SDR-xx's RS232 port can be used to control the radio from SpectraVue.

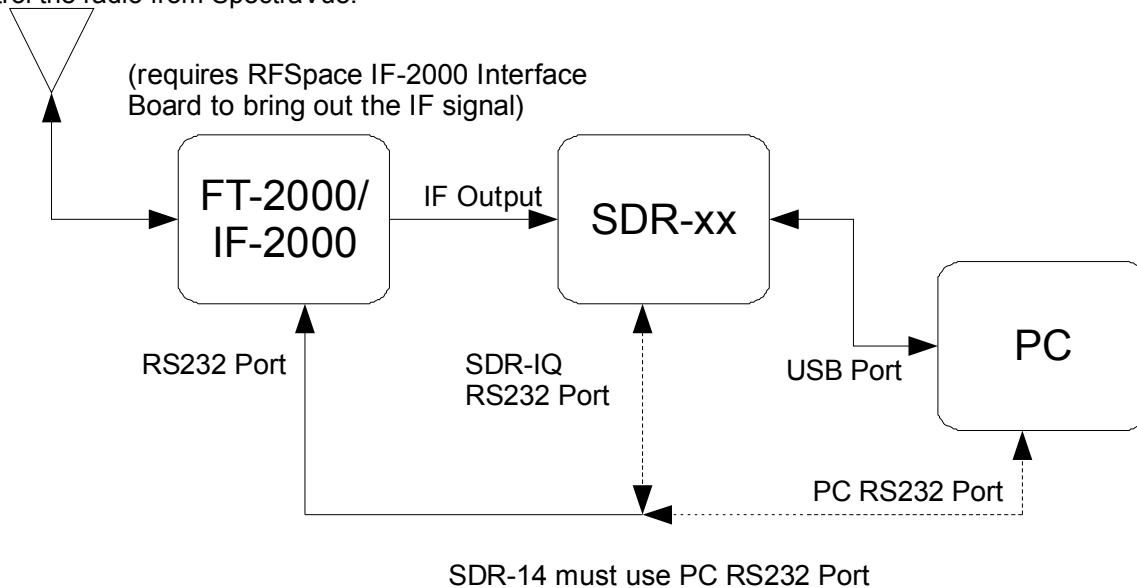

#### 4.5. Icom IC-R8500, IC-R7000, IC-R7100, IC-R9000

The following block diagram shows the basic setup for using the Icom IC-R8500,7000,7100,9000 receiver series with the SDR-xx and SpectraVue. If the SDR-14 is used, then the PC's serial port must be used, otherwise the SDR-xx's RS232 port can be used to control the radio from SpectraVue.

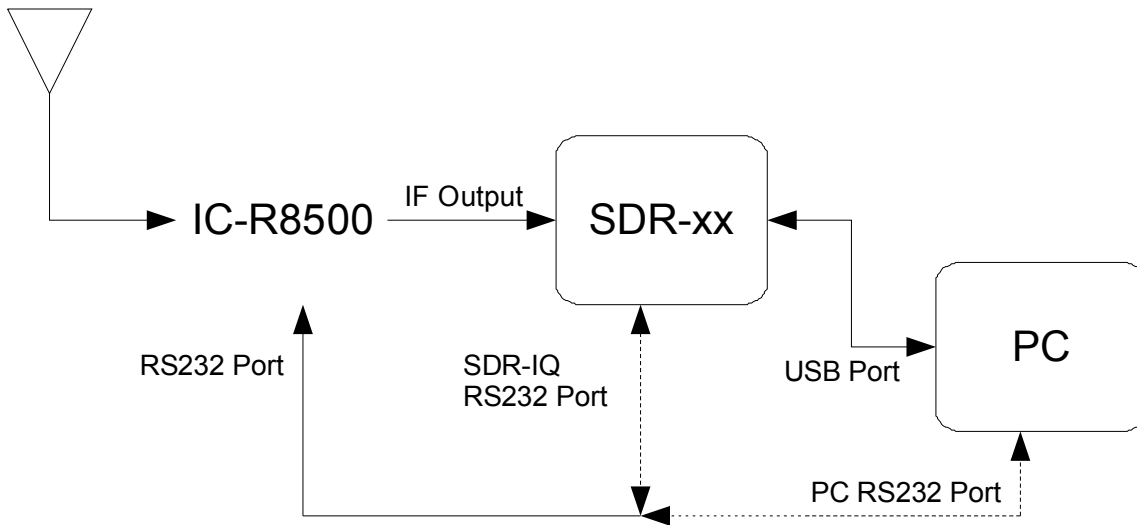

SDR-14 must use PC RS232 Port

**Note some Icom CI-V adapters are powered from the serial port DTR or RTS lines and will not work with the SDR-IQ serial port so the computer's COM port should be used.**

#### 4.6. Ten-Tec Orion-2(with User IF modification)

The following block diagram shows the basic setup for using the Orion-II transceiver with the SDR-xx and SpectraVue. If the SDR-14 is used, then the PC's serial port must be used, otherwise the SDR-xx's RS232 port can be used to control the radio from SpectraVue.

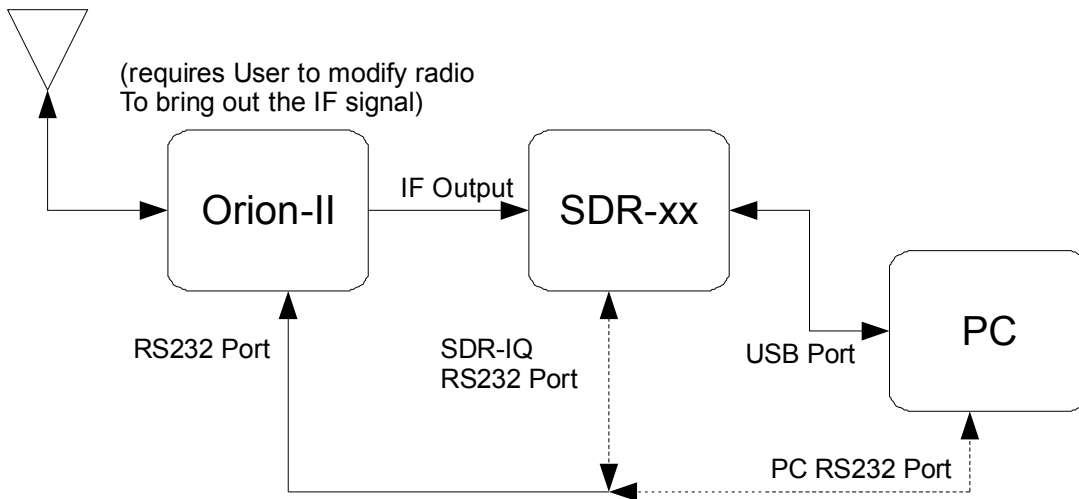

SDR-14 must use PC RS232 Port

#### 4.7. Icom IC-756PRO(with IF-2000 module)

The following block diagram shows the basic setup for using the IC-756PRO radio with the SDR-xx and SpectraVue. If the SDR-14 is used, then the PC's serial port must be used, otherwise the SDR-xx's RS232 port can be used to control the radio from SpectraVue.

The RFSpace IF-2000 interface board is required to be installed in the IC-756PRO receiver. This board converts the 64.455MHz IF of the IC-756PRO to 15.545Mhz that can be received by the SDR-xx. (80.0MHz LO)

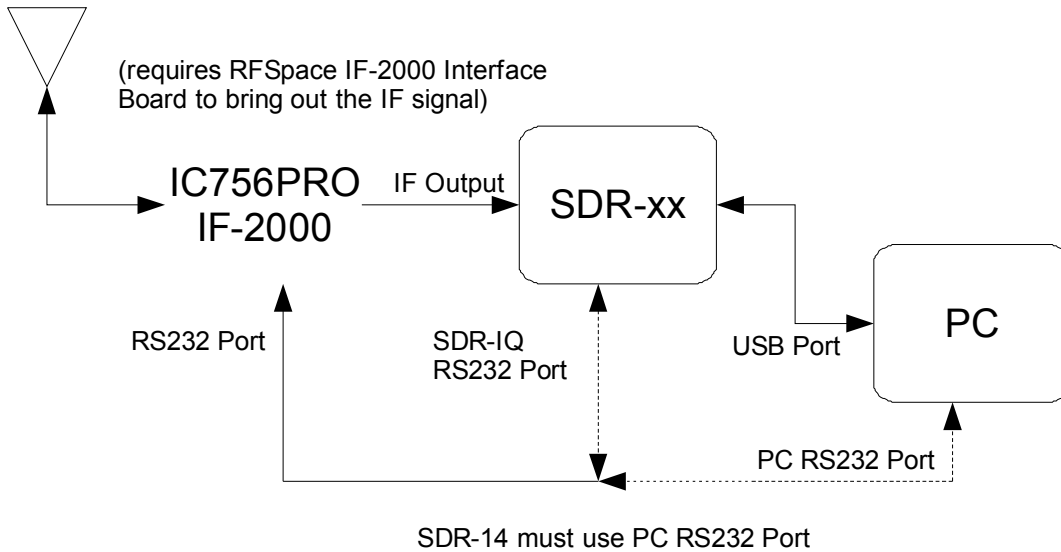

#### 4.8. Kenwood TS-870

The following block diagram shows the basic setup for using the TS-870 radio with the SDR-xx and SpectraVue. If the SDR-14 is used, then the PC's serial port must be used, otherwise the SDR-xx's RS232 port can be used to control the radio from SpectraVue.

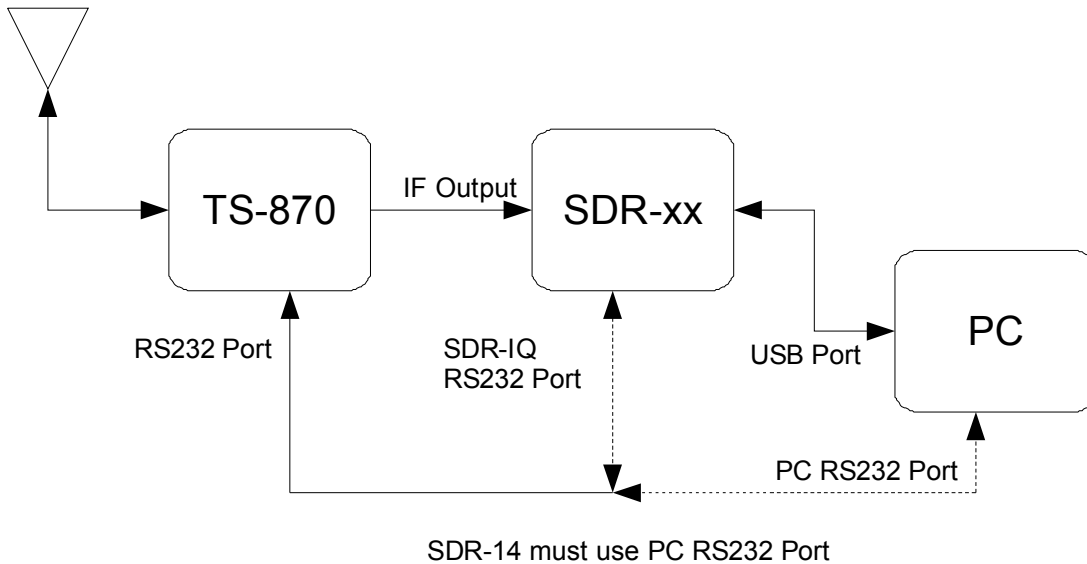

#### 4.9. Custom

The following block diagram shows the basic setup for using custom receiver with the SDR-xx and SpectraVue. This mode can be used if there is no RS232 control available such as in the case of a fixed down converter that for example converts 1296MHz to 21.7MHz IF. SpectraVue can then display the correct input frequency as it tunes within the IF bandwidth.

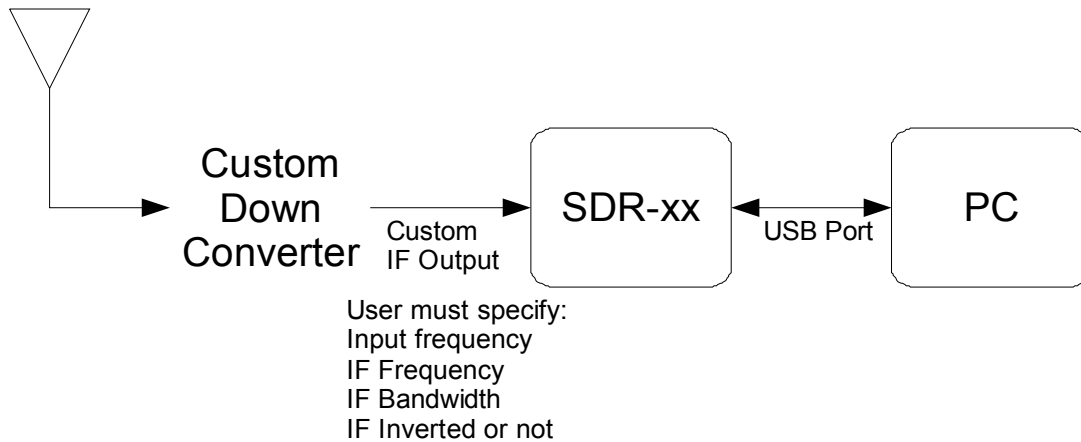

## 5. Timed Recording Formats

### 5.1. RIFF .wav File custom Format

SpectraVue saves the data captured from the SDR-xx devices in a RIFF .wav file format. A custom field is added to the normal RIFF header to include various parameters unique to storing RF data in a file normally used for audio data. The RIFF format allows the addition of custom “subchunks” of parameters because programs that read the files should ignore any fields that it does not recognize.

Google “Resource Interchange File Format” or RIFF to find details on the format specification.

SpectraVue adds a new subchunk called "auxi" that contains some custom information that is not really needed but is used by SV if present to deal with IF frequencies etc.

It consists of a block of data with the following structure:

```

typedef struct{
  SYSTEMTIME StartTime;
  SYSTEMTIME StopTime;
  DWORD CenterFreq;           //receiver center frequency
  DWORD ADFrequency;         //A/D sample frequency before downsampling
  DWORD IFFrequency;         //IF frequency if an external down converter is used
  DWORD Bandwidth;           //displayable BW if you want to limit the display to less than Nyquist band
  DWORD IQOffset;            //DC offset of the I and Q channels in 1/1000's of a count
  DWORD DBOffset;           //dB offset due to attenuators is 100*dBOffset.
  DWORD Unused3;
  DWORD Unused4;
  DWORD Unused5;
}AUXINFO;
  
```

The DWORDS are just 32bit values and SYSTEMTIME is 16 byte structure of seconds,minutes etc.

```

typedef struct _SYSTEMTIME {
  WORD wYear;
  WORD wMonth;
  WORD wDayOfWeek;
  WORD wDay;
  WORD wHour;
  WORD wMinute;
  WORD wSecond;
  WORD wMilliseconds;
} SYSTEMTIME;
  
```

Here is a file dump in hex of the .wav file header created by SpectraVue.  
 The 4 byte chunk size is highlighted in yellow. The blue green is the 4 byte Center frequency(14.205MHz). The red is the A/D sample frequency(66666667Hz). Blue is the first I/Q 16 bit data sample. In this case its 2 channels of 16 bit PCM data.

```

52494646 72C00300 57415645 666D7420 RIFFr WAVEfmt
12000000 01000200 EEFD0200 B8F70B00 ↓ @ @ €² q ǝ
04001000 00006175 78694400 0000D907 ◆ ▶ auxID J.
03000400 13000A00 09000800 0000D907 ♥ ◆ !! ☉ ○ ☐ J.
03000400 13000A00 09000900 000048C0 ♥ ◆ !! ☉ ○ ○ H L
D800AB40 F9030000 000030E6 02004103 † ½ @ -♥ 0μ A♥
000049FB FFFF0000 00000000 00000000 I√
00006461 746100C0 030091FF D8FF5BFF data L♥ æ † [
DDFF3800 F3FFE0FF 4D00D5FF 8DFFE3FF | 8 ≤ α M F i π
E6FF1600 F4FF0400 26000500 BEFF6B00 μ = † ◆ & † d k
  
```

### 5.2. FFT Absolute 2 byte Data .fft File custom Format

This is a raw binary format for saving the FFT data. The first 1024 bytes of the file is a header whose first 16 bytes contain specific information about the file data. All data is Little Endian binary format.

- 4 bytes Number of 16 bit data samples per FFT capture.
- 4 bytes FFT size
- 4 bytes FFT data sample rate in Hz
- 4 bytes Center frequency of FFT data.
- The remaining bytes in the 1024 byte header are 0.

Starting at file location 0x400(1024) the FFT data is placed as a 2 byte signed integer that represents the FFT data times 100. So for example a -135.23dB point would be saved as a 16-bit integer -13523, Little Endian word. All FFT points are saved regardless of the span so the next FFT line would begin at 0x400 + FFTSIZE for real FFTs or 0x400 + FFTSIZE\*2 for complex FFTs.

### 5.3. Continuum .csv Format

This format saves the continuum mode (power within the specified Span) in a comma separated format that can be imported into Excel for analysis. The first column is the data and time. The second column is the total power within the span, the third column is the peak power within the span in dBfs.

```

2009/03/19 14:45:36, -57.437, -71.133915
2009/03/19 14:45:36, -57.2626, -71.221365
2009/03/19 14:45:36, -57.1092, -69.933479
2009/03/19 14:45:36, -57.1404, -70.673458
2009/03/19 14:45:36, -57.228, -70.66663
2009/03/19 14:45:36, -57.1053, -70.421321
2009/03/19 14:45:36, -57.1099, -70.211351
2009/03/19 14:45:37, -57.2852, -71.462994
2009/03/19 14:45:37, -57.3217, -70.62351
2009/03/19 14:45:37, -57.3061, -70.362563
2009/03/19 14:45:37, -57.1225, -71.266175
  
```

### 5.4. FFT Data Excel Comma separated.csv custom Format

The .csv custom FFT data format saves the entire FFT data in comma separated format at specified intervals. The first line is the frequency in Hz of each of the FFT bins. The remaining lines contain the power in dBfs of each of the FFT bins.

```

14110000, 14110095.74, 14110191.48, 14110287.22, .....
  
```



-86.4015, -89.5287, -88.0267, -84.0764, -82.7818, .....  
-89.6693, -86.9297, -85.962, -87.7725, -91.0202, .....  
-90.9418, -87.6847, -93.1511, -87.1616, -87.9857, .....  
-88.3724, -84.7777, -88.5428, -87.5818, -91.0386, .....  
-87.7971, -86.3141, -87.2955, -82.7011, -81.7949, .....

## 6. Pulse Mode

## 7. Network Operation

The SDR-xx can be interfaced to SpectraVue over a network. By running a server utility program (SDRxxServer) on a remote PC, and SpectraVue on another PC, one can access the SDR-xx over a wired or wireless network connection.

### Remote SDR-xx Operation Using Network

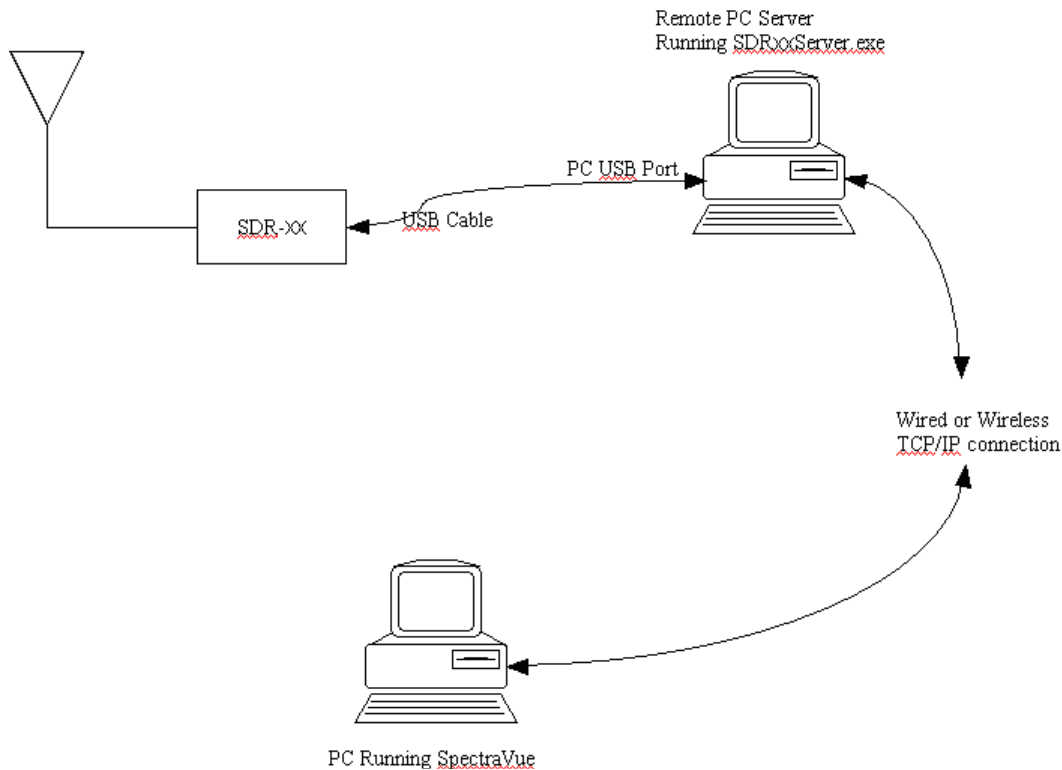

### Network Setup Steps:

1. SpectraVue should be installed on the remote PC even though it is not going to be used since the USB drivers are required by the SDRxx server application. On the remote PC, run the utility program "SDRxxServer.exe" that should be installed in the main SpectraVue folder. . It is also available separately on the [www.moetronix.com](http://www.moetronix.com) web pages.

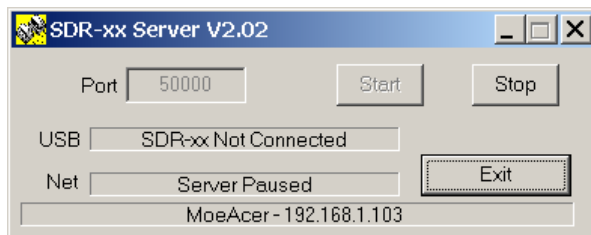

2. Connect the SDR-xx USB cable to the remote PC and apply power to the SDR-xx if required. The server should connect to the SDR-xx and the following status should result.

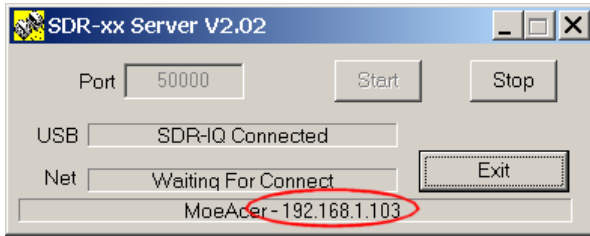

Make a note of the IP address of the PC that is displayed at the bottom of the Server program. In this example it is 192.168.1.103

3. Go to the Client PC and bring up SpectraVue and open the SDR-xx Setup menu. Enter the remote PC's IP address that was displayed on the SDRxxServer application on the remote PC into the edit box at the lower right hand part of the menu screen.

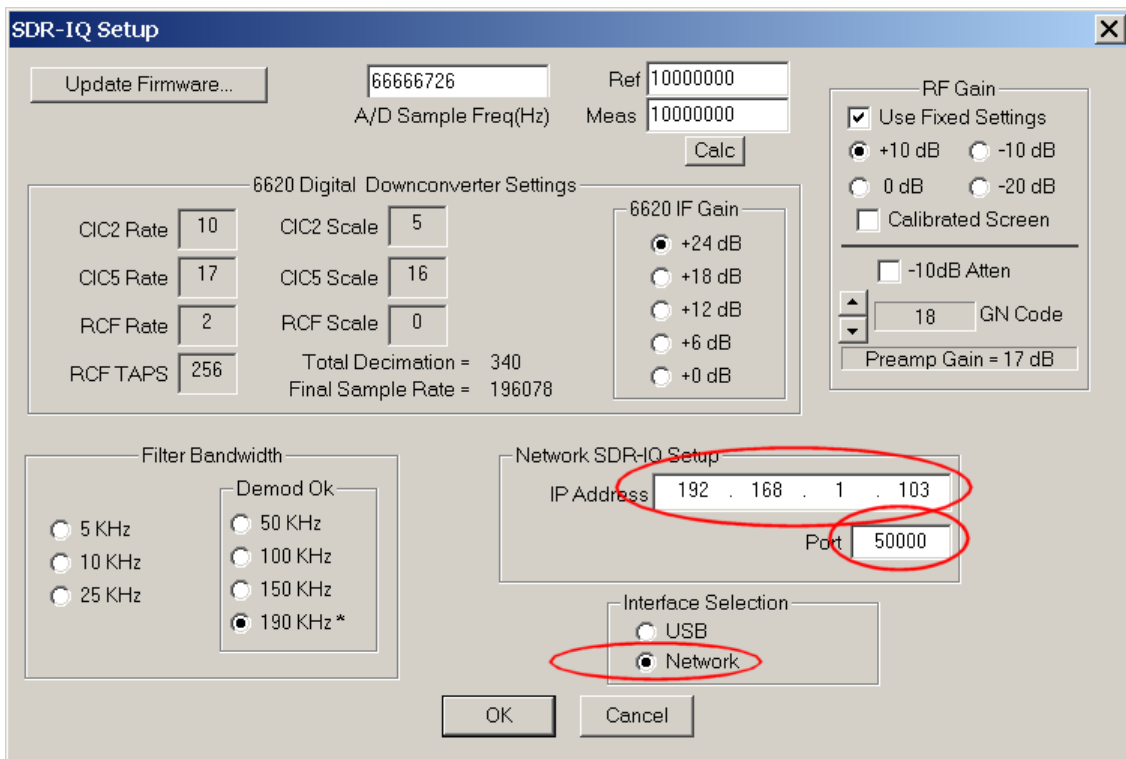

Make sure the Port Number matches that of the server application and Spectravue. The default is 50000 and there is probably no reason to change. After exiting the setup menu, SpectraVue should connect to the remote SDR-xx and on the remote computer, the following status should be displayed (with the remote PC's IP address displayed)

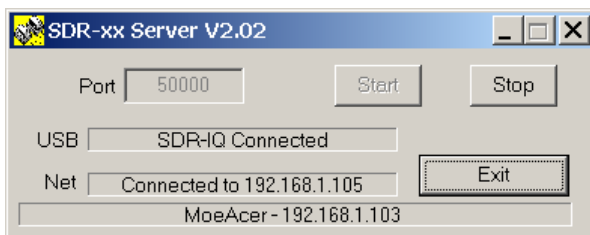

SpectraVue should now be able to run the remote SDR-xx as if it were directly connected to the PC.

**Note:**

***Trying to connect over slow network connections such as the Internet or 802.11b systems, will not work since the data rates are too high. Use a wired Ethernet or 802.11g high speed network connection.***

To aid in testing out a system, one can run SpectraVue on the same remote PC that the SDR14Server is running on and use the loopback IP address of 127.0.0.1. The SDR-xx data will loopback through the PC network stack and one can verify that the remote server and SpectraVue setup is working before trying to debug a network system.

## 8. Hints and Tricks

### 8.1. Frequency Calibration

The following ideas are presented to help one calibrate the SDR-xx and SpectraVue for applications where frequency or power accuracy is needed.

The internal sample clock of the SDR-xx is a crystal oscillator running at a nominal frequency of 66.666...Mhz or 80.00000MHz. It is not oven controlled or adjustable so some means is needed to correct for it in SpectraVue.

The easiest way to calibrate is to input a known reference frequency into the SDR-xx and accurately measure it using SpectraVue. The difference in the measured and actual frequency can then be used to change the value SpectraVue uses for the sample clock. WWV can be used if a decent signal is available or a good lab source. A local AM station carrier could also be used to get reasonably close.

The following SpectraVue setup can be used to help calibrate the system.

1. Setup SDR-xx for a 50Khz BW, and set the A/D Sample Frequency to nominal of 66666667Hz or 80000000Hz depending on the SDR model if not already there. It doesn't have to be but for this example it is what it would be the first calibration time.

The screenshot shows the 'SDR-14 Setup' dialog box with the following settings:

- A/D Sample Freq(Hz):** 66666667 (circled in red)
- Ref:** 10000000 (circled in red)
- Meas:** 10000000
- RF Input Source:** 0-30 MHz (ch 1) (selected)
- 6620 Digital Downconverter Settings:**
  - CIC2 Rate: 8, CIC2 Scale: 4
  - CIC5 Rate: 30, CIC5 Scale: 20
  - RCF Rate: 5, RCF Scale: 0
  - RCF TAPS: 256
  - Total Decimation = 1200, Final Sample Rate = 55555
  - 6620 IF Gain: +24 dB (selected), +18 dB, +12 dB, +6 dB, +0 dB
  - Ch 1 RF Gain: 0 dB (selected), -10 dB, -20 dB, -30 dB
  - Calibrated Screen:
- Filter Bandwidth:** 50 KHz (selected)
- Demod Ok:** 50 KHz (selected)
- Network SDR-14 Setup:** IP Address: 192 . 168 . 1 . 100, Port: 50000
- Interface Selection:** USB (selected)

Buttons: Update Firmware..., External HW Sync, Calc, OK, Cancel.

2. Set the General Setup menu as shown with the "Display Peak Markers" button checked and the Exclude to around 10%.

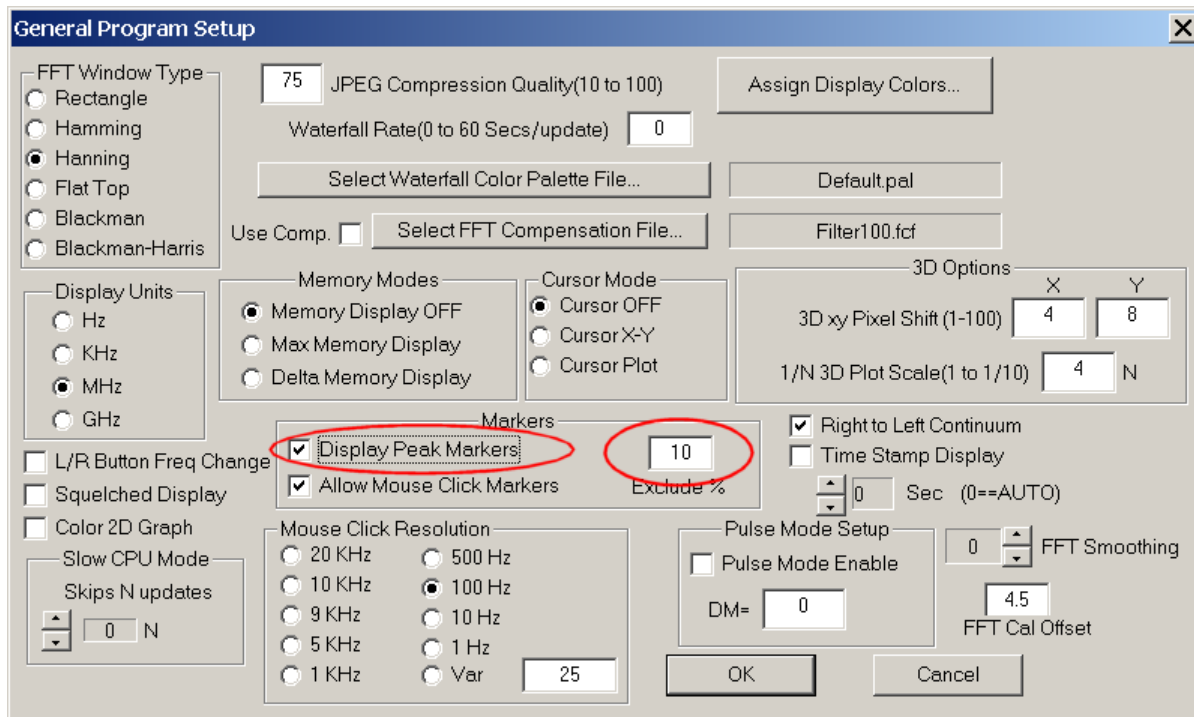

3. Setup the main screen as follows with an FFT size of 65536, an average of 5 or so, a center frequency of 10MHz(for WWV), demod OFF, and a span of 500Hz.. Press Start and adjust the screen to allow easy viewing of the 10MHz peak. Note the little red mark on the peak and its corresponding marker frequency of 9.9999979Mhz in the status bar. This is the measured frequency of WWV and shows that the program is off by about 3Hz.

Remember the program can only measure frequency as accurately as the FFT BW resolution so make sure you use a large enough FFT to get within 1 Hz or so. The example shows a .85Hz RBW so is ok.

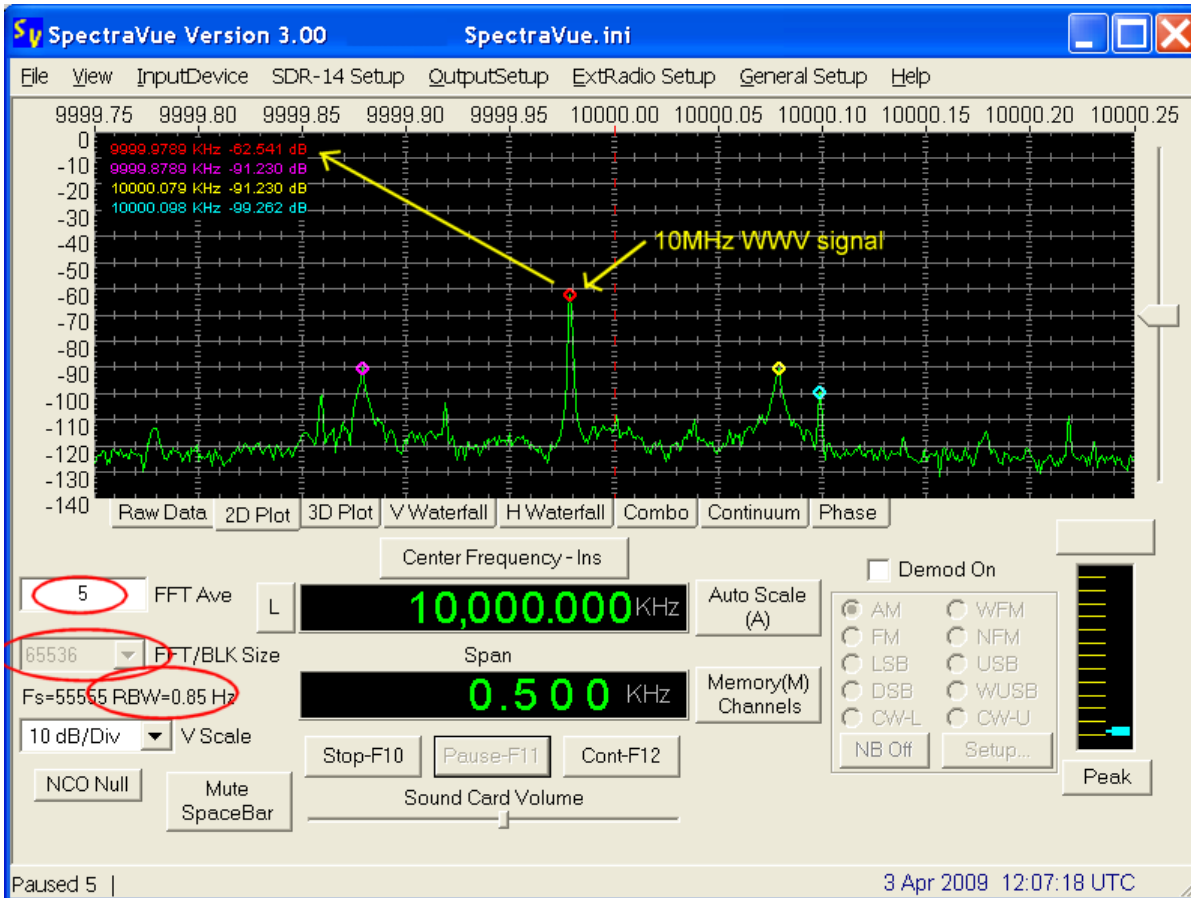

4. Stop or pause the capturing and open the SDR-xx Setup menu. Notice the measured frequency has been automatically placed in the box(if you had peak markers checked and it was marking the correct reference peak) One can manually enter the Reference and Meas frequencies if not using a 10MHz reference.

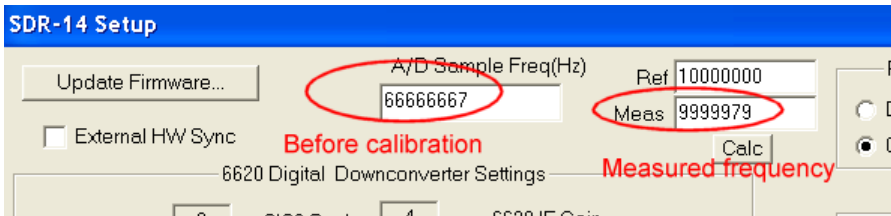

5. Click on the "Calc" button and the new A/D Sample Frequency is calculated. The "Meas" box will revert to the Ref frequency so one doesn't accidentally keep scaling the A/D sample frequency.

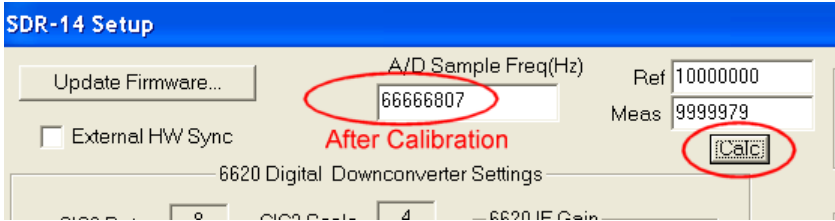

6. Go back to the main screen and start the captures again to verify that the new calibration has taken effect. One may have to perform this a few times to iterate the error to zero if the signal is noisy or the SDR-xx is still warming up.

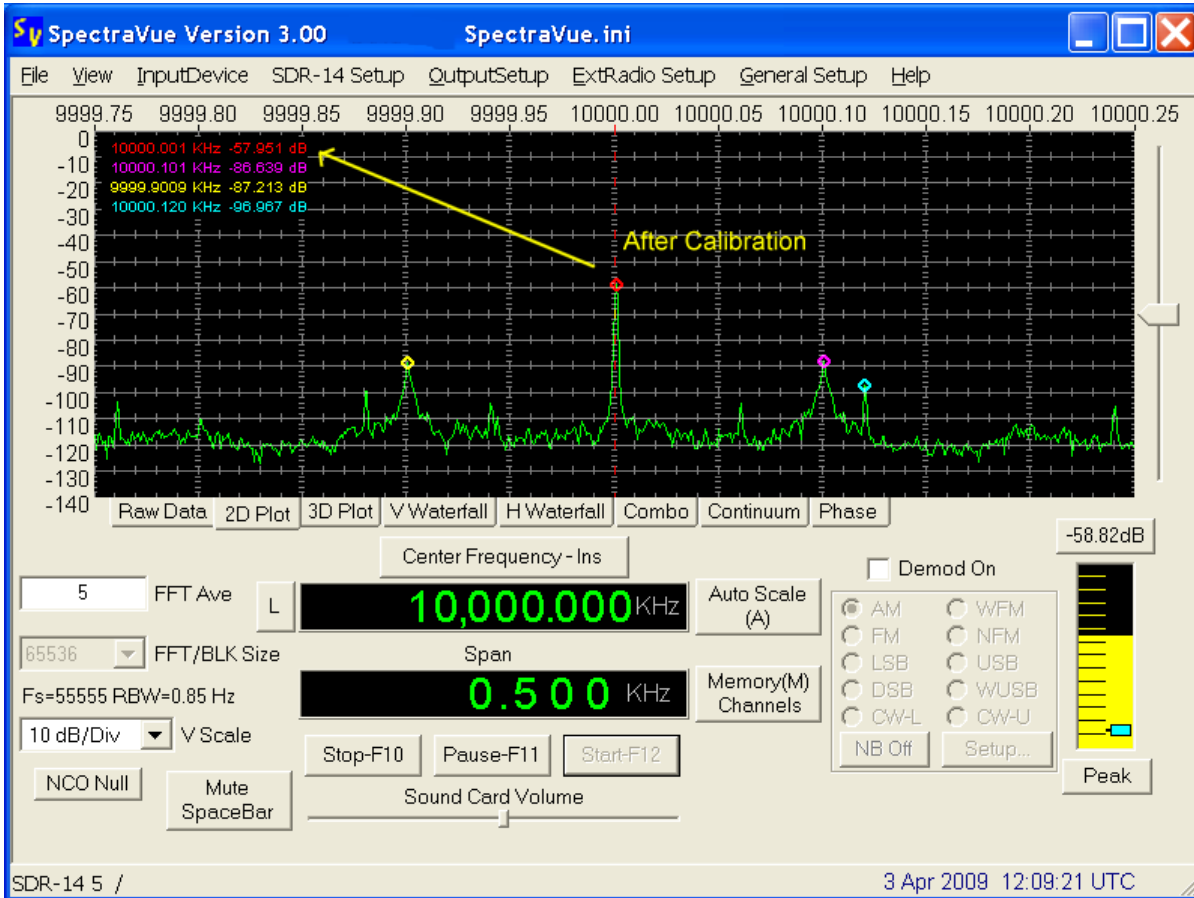



## 8.2. Amplitude Calibration

The easiest way to calibrate the SDR-xx and SpectraVue for power amplitude is to simply input a sine wave signal of known power and adjust the "FFT Max dB" value in the FFT setup menu. This number is simply added to all the screen values.

For example, set the signal generator to say -20dBm and measure the amplitude shown on the 2D FFT screen. Use the Peak Markers for best accuracy rather than the cursor marker since the screen resolution is not very accurate. Enter a value into the "FFT Max dB" edit box in the FFT setup menu that when added to the measured value will make it display -20dBm. The value can be positive or negative.

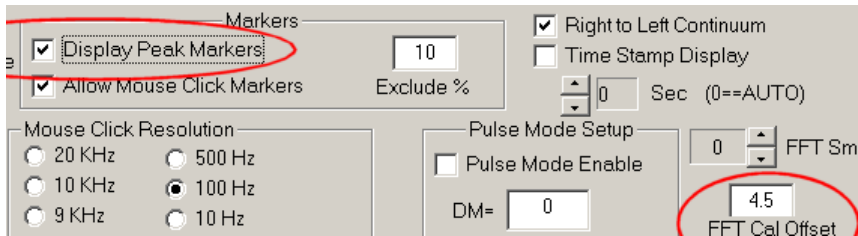

In the direct input mode of the SDR-14, a value of 4.5dB will be very close since this is the level in dBm where the A/D begins to clip. If the internal preamp or an external one is used, then one must change the value accordingly.

## 8.3. Multiple Spectravue Instances

Spectravue normally does not allow multiple instances of it running at the same time. However if one copies and renames the file "Spectravue.exe" to say "Spectravue1.exe" and another copy to "Spectravue2.exe", then both of these new programs will run independently. A separate settings .ini file will be created and used for each program name. Also a separate Windows registry entry will be created to store the program size and position for each instance.

**Note: Running multiple instances and multiple SDR-xx's can use a lot of CPU time so a fast PC is required.**

## 8.4. Managing Frequency Memories

There are 20 memory buttons in Spectravue that can be programmed with various frequencies and modes. These memory channels are stored in the SpectraVue.ini settings file.

If more memories are needed, then the Setup .ini file can be saved to a different name instead of the default spectravue.ini file name. This new file can then be recalled and load in a new set of memories. Using this technique, one can have as many memory groups as they want by saving to different .ini file names.

For example one could save 20 memory channels for the 40m amateur band in a file called "Ham40meter.ini". Then save 20 channels of public service band frequencies to a file called "pubservice.ini".

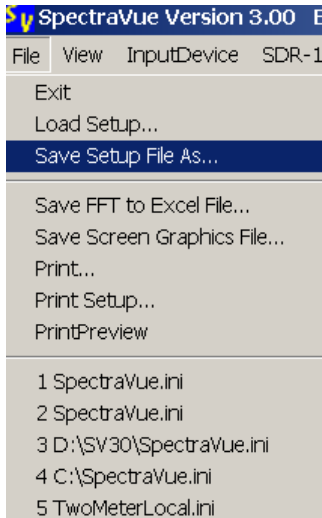

Note SV keeps a short list of 5 most recently used .ini files so one can quickly change from one to another.

## 9. External SpectraVue Control Messages

Spectravue exposes a limited number of control items to 3<sup>rd</sup> party programs using a registered message system.

### 9.1. Registered Message

The registered message string used is "SpectraVueExtMsg"

```
#define SV_REGISTERED_MSG_STRING "SpectraVueExtMsg"
```

In Microsoft C++ the following line is used to obtain a registered message value

```
// Registered window message for external process control
```

```
const UINT wm_SVMessage = RegisterWindowMessage( _T(SV_REGISTERED_MSG_STRING) );
```

#### 9.1.1. Example Message Handler

The following message handler macro can be defined

```
ON_REGISTERED_MESSAGE( wm_SVMessage, OnSVMessage)
```

An example service routine for messages coming from SpectraVue

```
// Handler for registered window message wm_SVMessage
```

```
// which is posted to all top-level windows in the system
```

```
// when communicating with an external process
```

```
// wParam contains the command and lParam the data.
```

```
LRESULT CSVExtControlDlg::OnSVMessage(WPARAM Cmd, LPARAM Data)
```

```
{
```

```
    // If message is posted from this process do nothing
```

```
    if ( !(Cmd & SV_TO_EXTERNAL) )
```

```
        return 0;
```

```
    Cmd &= ~SV_TO_EXTERNAL;           //get rid of msb flag
```

```
    switch(Cmd)
```

```
    {
```

```
        case SVCMD_STATUS:
```

```
            switch(Data)
```

```
            {
```

```
                case SV_STATUS_OFFLINE:
```

```
                    m_StatusTxtCtrl.SetWindowText("Offline");
```

```
                    break;
```

```
                case SV_STATUS_IDLE:
```

```
                    m_StatusTxtCtrl.SetWindowText("Idle");
```

```
                    break;
```

```
                case SV_STATUS_PAUSED:
```

```
                    m_StatusTxtCtrl.SetWindowText("Paused");
```

```
                    break;
```

```
                case SV_STATUS_RUNNING:
```

```
                    m_StatusTxtCtrl.SetWindowText("Running");
```

```
                    break;
```

```
            }
```

```

        break;
    case SVCMD_SET_CENTER_FREQ:
        m_CFreq = Data;
        break;
    case SVCMD_SET_SPAN_FREQ:
        m_SpanFreq = Data;
        break;
    case SVCMD_DEMOD_0_FREQ:
        m_DemodFreq0 = Data;
        break;
    case SVCMD_DEMOD_1_FREQ:
        m_DemodFreq1 = Data;
        break;
    case SVCMD_DEMOD_MODE:
        m_DemodGroup = Data;
        break;
}
return 0;
}

```

### 9.1.2. Example Message Sending

Example of sending a center frequency command to SpectraVue

```
::PostMessage(HWND_BROADCAST, wm_SVMessage, (WPARAM)SVCMD_SET_CENTER_FREQ, m_CFreq);
```

## 9.2. Available Command Definitions

The following command definitions are available and a .h include file is provided in the Spectravue installation containing the supported commands:

```

#define SV_REGISTERED_MSG_STRING "SpectraVueExtMsg"
#define SV_TO_EXTERNAL (1<<31) //bit "OR'd" with SVCMD_xxx to distinguish msgs coming from SV
#define SVCMD_STATUS 0x10 //Status values from SV
#define SV_STATUS_OFFLINE 0
#define SV_STATUS_IDLE 1
#define SV_STATUS_PAUSED 2
#define SV_STATUS_RUNNING 3
#define SVCMD_SQUELCH 0x18 //cmd Squelch State value to/from SV
//if zero data sent to SV then audio is muted
#define SVCMD_START 0x20 //cmd to SV to start/resume running
#define SVCMD_PAUSE 0x30 //cmd to SV to pause running
#define SVCMD_STOP 0x40 //cmd to SV to stop running
#define SVCMD_DEMOD_STATE 0x48 //cmd to/from SV demodulation on and off
#define SV_DEMOD_OFF 0
#define SV_DEMOD_ON 1
#define SVCMD_SET_CENTER_FREQ 0x50 //cmd to/from SV's center frequency
#define SVCMD_SET_SPAN_FREQ 0x60 //cmd to/from SV's span frequency range
#define SVCMD_DEMOD_0_FREQ 0x70 //cmd to/from SV's channel 0 demod frequency

```

```

#define SVCMD_DEMOD_1_FREQ          0x71    //cmd to/from SV's channel 1 demod frequency
#define SVCMD_DEMOD_MODE            0x80    //cmd to/from SV's demod mode
#define SV_DEMOD_AM 0                //demod types
#define SV_DEMOD_WBFM 1
#define SV_DEMOD_FM 2
#define SV_DEMOD_USB 3
#define SV_DEMOD_LSB 4
#define SV_DEMOD_CWU 5
#define SV_DEMOD_CWL 6
#define SV_DEMOD_DSB 7
#define SV_DEMOD_NFM 8
#define SVCMD_SET_RFGAIN 0x90        //cmd to/from SV RF Gain setting
#define SV_RFGAIN_0 0
#define SV_RFGAIN_M10 1
#define SV_RFGAIN_M20 2
#define SV_RFGAIN_M30 3
#define SVCMD_SET_IFGAIN 0x98        //cmd to/from SV RF Gain setting
#define SV_IFGAIN_24 0
#define SV_IFGAIN_18 1
#define SV_IFGAIN_12 2
#define SV_IFGAIN_6 3
#define SV_IFGAIN_0 4

```