



Station Description

24 Jun 2017

Dave Typinski

CONTENTS

Observatory Outline	1
TFD Array Schematic	4
TFD Array Feed Losses	5
TFD Array Element Sweeps	6
Riometer Array Schematic	8
Riometer Array Feed Losses	9
Riometer Array Element Sweeps	10
Antenna Feed Control	12
Receivers	13
Calibration Temperatures – TFD Array	14
Calibration Temperatures – Riometer Array	15
Power Distribution	16
TFD Array Beam Steering	17
Terrestrial Beam Heading Map	23
Magnetic Declination	24
Facility Layout	26
Location Within North America	27



26211 W US Hwy 27
PO Box 2423
High Springs, FL 32655

Contact: Dave Typinski
davetyp@typnet.net
(386)344-3166

OBSERVATORY OUTLINE

Location

29° 50' 13" N 29.8369° N EL89qu
82° 37' 17" W 82.6214° W
53 ft (16 m) MSL

Antennas

TFD Array

Two square arrays on a NS line, eight 30-foot TFD elements, beam steering in 5° increments NS and 15° increments EW.

16 MHz HPBW at zenith: 18° NS x 40° EW

20 MHz HPBW at zenith: 15° NS x 35° EW, D ≈ 14 dBic

24 MHz HPBW at zenith: 12° NS x 30° EW

32 MHz HPBW at zenith: 8° NS x 20° EW

For more about the TFD Array, see: [The DPS and TFD Array](#)

Riometer Array

Standard Radio Jove dual-dipole array, 20' element spacing, 12' wire height, 23'1" driven elements, 24'4" reflectors 7'6" directly beneath driven elements, no phasing (zenith beam steering).

20 MHz HPBW at zenith: 72° NS x 74° EW, D ≈ 8.3 dBi

Receivers

Dual Polarization Spectrograph (DPS)

24 x 7 x 365 unattended operation

16–32 MHz, simultaneous (correlated) RCP and LCP

300 channels per polarization (600 total)

Swept frequency, selectable 7.5, 15, 30, 60 kHz pre-detection BW

~ 6.7 sweeps/sec, integration time = 500 μs per sample

Frequency resolution = 53 kHz, Δt = 150 ms

For more about the DPS, see: [The DPS and TFD Array](#)

Receivers (cont'd)

Radio Jove Receivers

24 x 7 x 365 unattended operation
~ 20.1 MHz, uncorrelated RCP and LCP
7 kHz RF BW folded via direct conversion into a baseband
3.5 kHz pre-detection audio BW
Integration time = 100 ms per sample
For more about the Jove Receivers, See: [Radio Jove Receiver Manual](#)

Icom R8500 + 10.7 MHz Jove Receiver

24 x 7 x 365 unattended operation
20.1 MHz, East-West linear polarization
7 kHz RF BW folded via direct conversion into a baseband
3.5 kHz pre-detection BW
Integration time = 100 ms per sample

Tunable Wideband Receiver (TWB) Mark III

Attended operation only
Tunable from 16 to 32 MHz, RCP or LCP
2 MHz IF BW direct to high speed digitizer
FFT post-processing, RBW = 4.88 kHz, $\Delta t = 205 \mu\text{s}$
For more about the TWB, see: [The TWB](#)

Sensitivity

Formal sensitivity calculations and measurements have not been made. A rough estimate considering only the number of dipoles is a 20 MHz on-axis and at zenith 3σ sensitivity on the order of 100 kJy. All receivers presently in use have noise figures between 6 and 8 dB, making their internal noise of little concern given the modest losses between the TFD array and the receivers and the fact that in the upper HF band, system noise is dominated by the galactic background emission.

Timing

All radio telescope data collection systems use a PC's internal clock to apply timestamps to the data. Each PC runs a service, Meinberg NTP daemon, to keep its system clock within a few milliseconds of UTC using Network Time Protocol (NTP). The NTP server is a GPS-ntp-pi stand-alone unit using GPS and GLONASS signals to determine and provide the correct time on the local network. Future work includes upgrading the spectrographs to a GPS-based hardware system with firmware modification to keep the start of each frequency sweep disciplined to within a hundred nanoseconds of UTC. For more information, see: [GPS-NTP Pi](#)
For more information, see: [Meinberg NTP Server](#) and [Meinberg NTP Server Monitor](#)

Calibration

All radio telescope systems are calibrated in terms of antenna temperature using a noise source of known temperature calibrated against a 5722 noise diode. An automatic calibrator runs a step calibration on all receivers a fixed number of hours before and after Jupiter transit (usually 3 hours when Jupiter's elongation is $< 90^\circ$ and 4.5 hours when Jupiter's elongation is $> 90^\circ$), every day. The step cal runs in 17 steps of 5 seconds each separated by 3 dB, ranging from 4.3 kK to 250 MK equivalent antenna temperature.

For more information see: [5722 Noise Generator](#)

For more information see: [AJ4CO Automatic Calibrator](#)

Computers

Three identical PCs are used to record data from the receivers. Each has a 2.4 GHz AMD Opteron dual-core processor, 4 GB RAM, and a 1 TB hard drive. All run Windows XP SP3. All are connected to the observatory LAN.

Internet

The observatory has internet access via a 6 Mbps DSL connection. This connection allows the Radio Sky Pipe (RSS) and Radio Sky Spectrograph (RSS) software to serve data to interested remote observers.

Power

The receivers, computers, and network hardware are fed by three 1.5 kVA battery backup units providing at least 15 minutes of power if the AC mains fail.

Operations

Several radio telescopes operate all day, every day (see "Receivers" above). Useful Jupiter observations are made any time Jupiter is within 3 hours of transit, but this is extended to around 4.5 hours when Jupiter's transit elevation is greater than 70° and Jupiter is near opposition.

North

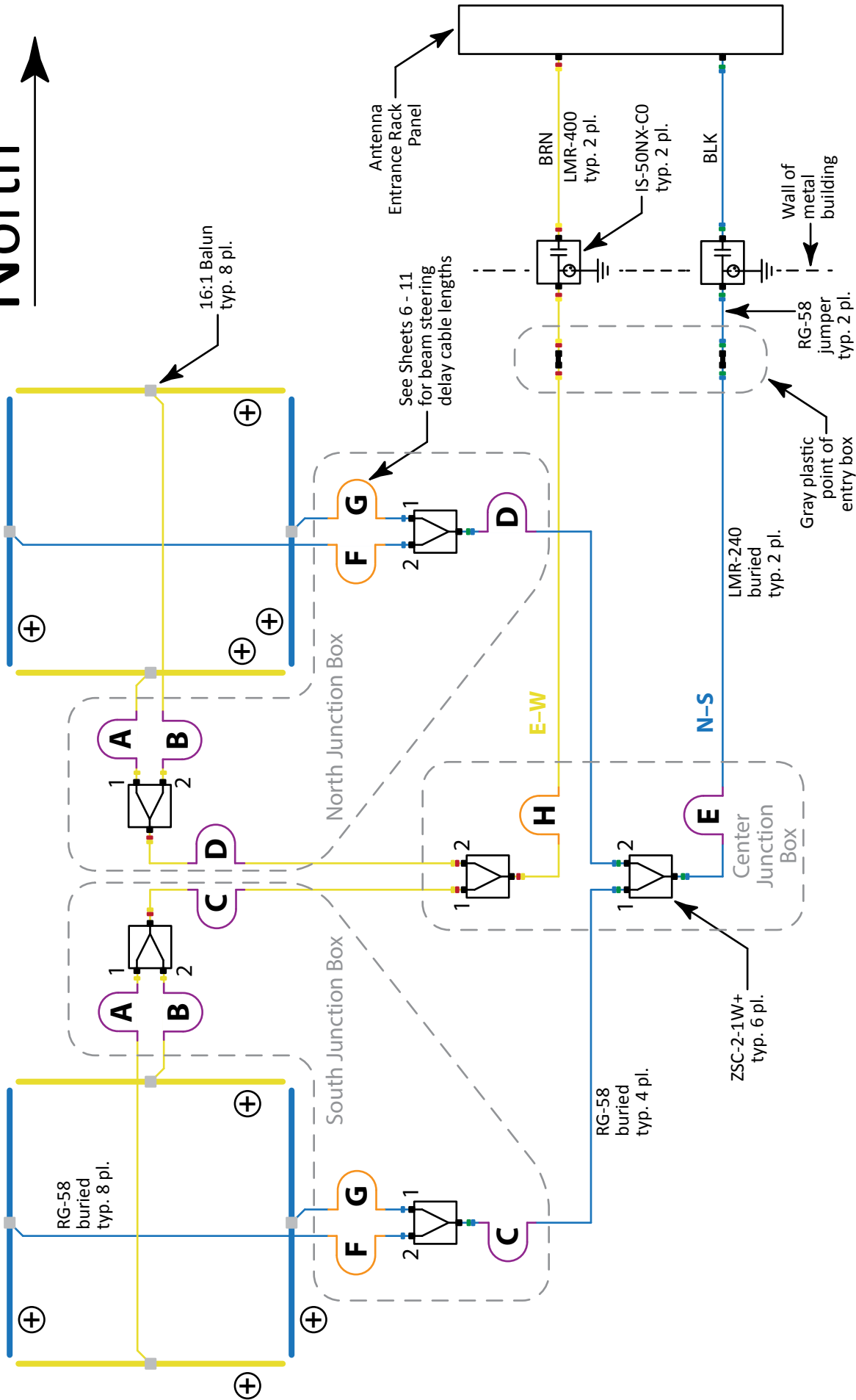

30' folded dipoles, top wire 9'2" height,
8' wire spacing, 32' element spacing,
800 Ω termination resistors, 16:1 baluns.

TFD Array - Electrical



SIZE	DATE	PART NUMBER	REV
A	28 MAR 2015	N/A	A
SCALE	NONE	DRAWN BY	SHEET
		DAVE TYPINSKI	1 OF 1

TFD Array Feed System Losses

Feed line loss sweeps performed 28 Mar 2015

Device sweeps performed 11 Aug 2013

Freq (MHz)	Rack panel to gray point of entry box LMR-400	Gray box to center J-box LMR-240	Center J-box to outer J-box RG-58	Outer J-box to element balun RG-58	AJ4CO BALUN16-1A 16:1 Balun (one)	Mini-Circuits ZSC-2-1W+ Combiners (two)	Loss Between Element Feed Points and Hybrid Inputs (CAL PLANE) (dB)	Synergy DQK-701B 90° Hybrid (one)
	One Way Loss (dB)	One Way Loss (dB)	One Way Loss (dB)	One Way Loss (dB)	Loss (dB)	Loss (dB)	Loss (dB)	Loss (dB)
16	-0.99	-0.94	-0.75	-0.33	-0.52	-0.40	-3.9	-0.21
18	-1.04	-0.99	-0.79	-0.35	-0.54	-0.41	-4.1	-0.26
20	-1.09	-1.03	-0.84	-0.37	-0.55	-0.42	-4.3	-0.29
22	-1.15	-1.07	-0.89	-0.39	-0.57	-0.43	-4.5	-0.32
24	-1.20	-1.11	-0.93	-0.40	-0.58	-0.44	-4.7	-0.34
26	-1.24	-1.16	-0.97	-0.42	-0.59	-0.45	-4.8	-0.34
28	-1.28	-1.20	-1.00	-0.45	-0.60	-0.47	-5.0	-0.32
30	-1.32	-1.23	-1.04	-0.46	-0.61	-0.49	-5.2	-0.30
32	-1.36	-1.27	-1.09	-0.46	-0.62	-0.50	-5.3	-0.27



TFD Array Feed System Losses

SIZE	DATE	PART NUMBER	REV
A	25 FEB 2017	N/A	A
SCALE	NONE	DRAWN BY	SHEET
		DAVE TYPINSKI	1 OF 1

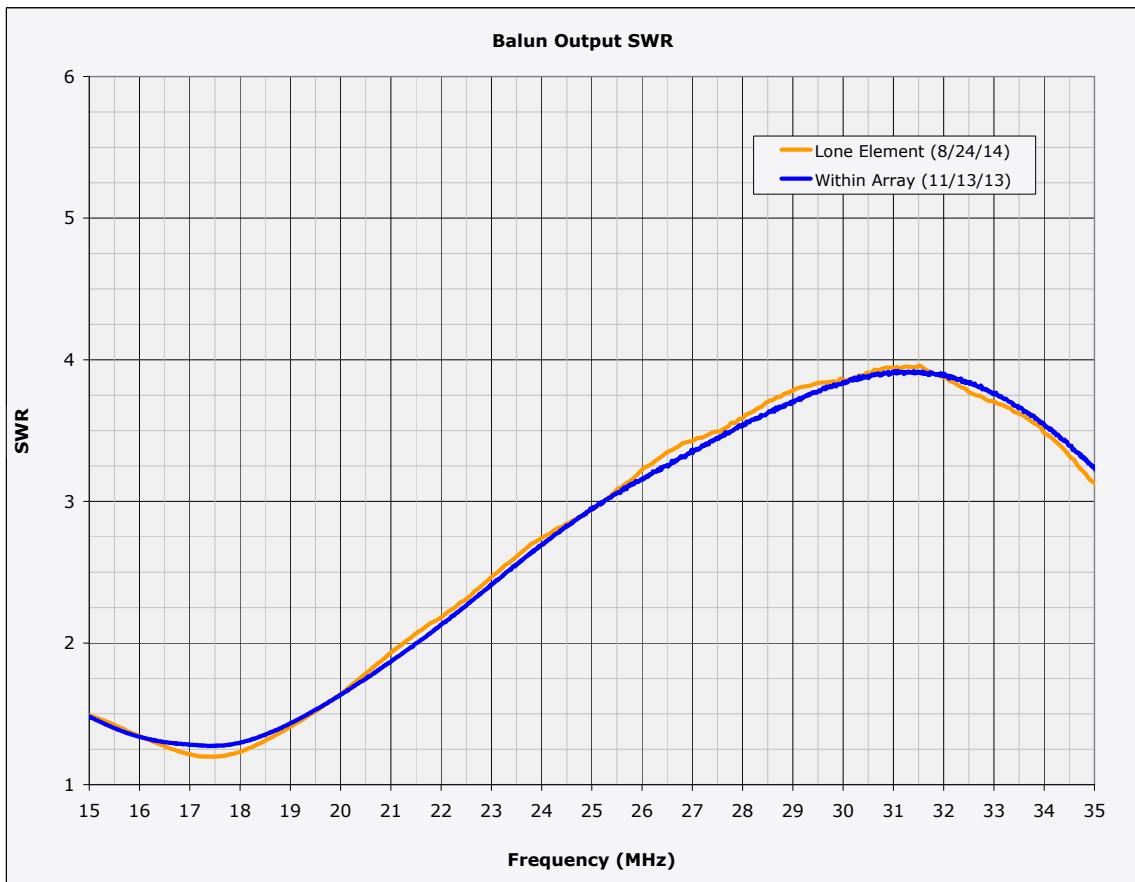
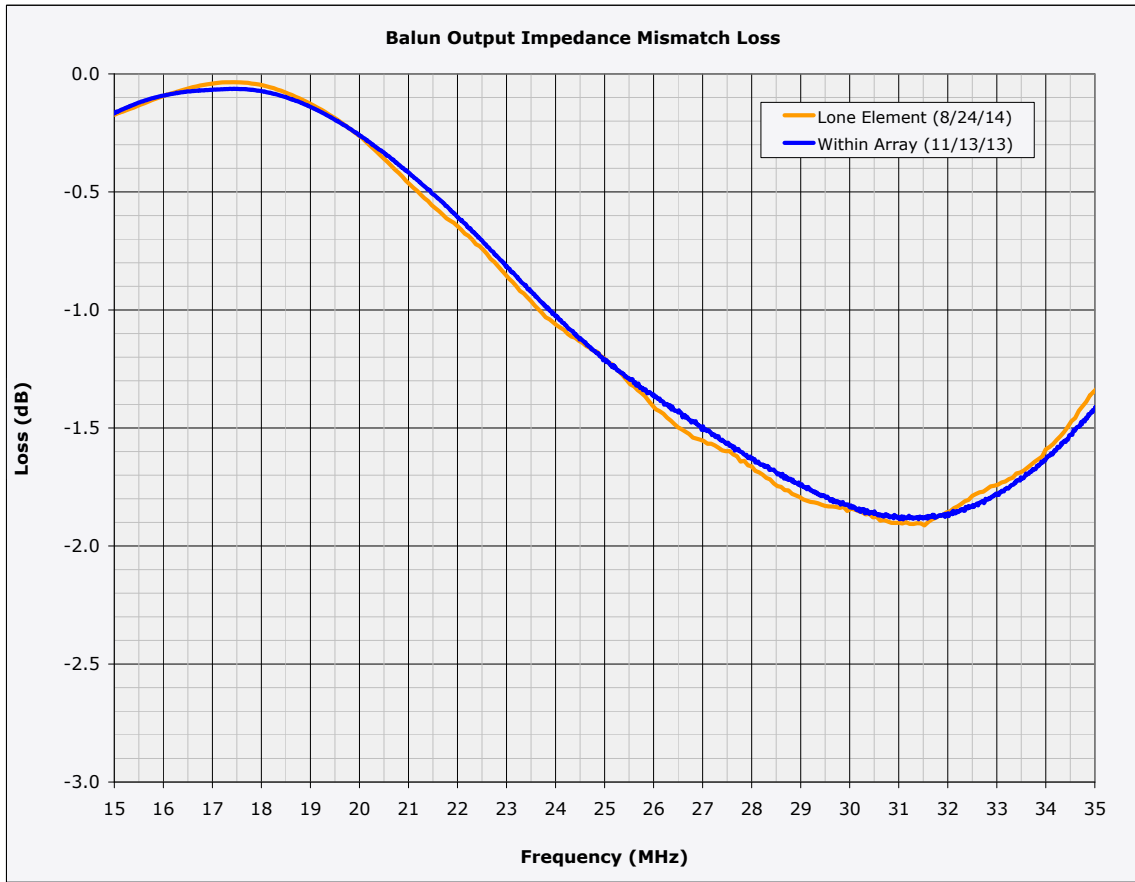

TFD Array 30' Element Sweeps



SIZE	DATE	PART NUMBER	REV
A	24 AUG 2014	N/A	A
SCALE	DRAWN BY	SHEET	1 OF 2
NONE	DAVE TYPINSKI	1	

Element sweeps performed with a VNA-2180.

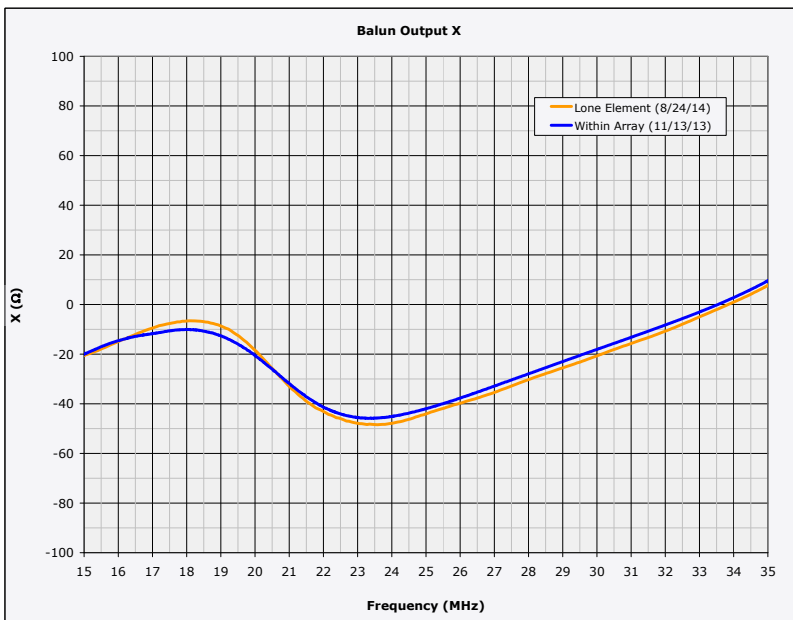
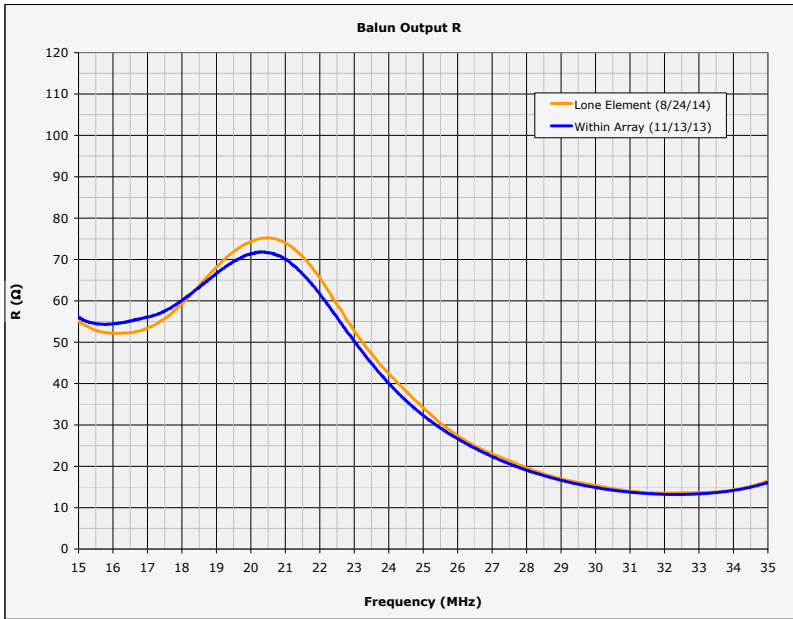
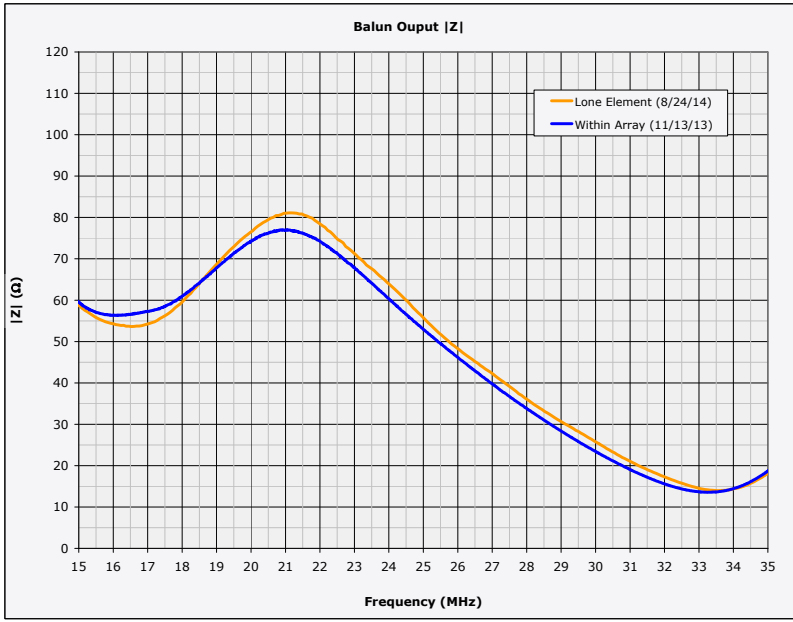

TFD Array Element Sweeps

REV	A
PART NUMBER	N/A
DATE	24 AUG 2014
SCALE	NONE
DRAWN BY	DAVE TYPINSKI
SHEET	2 OF 2

Element sweeps performed with a VNA-2180.

North

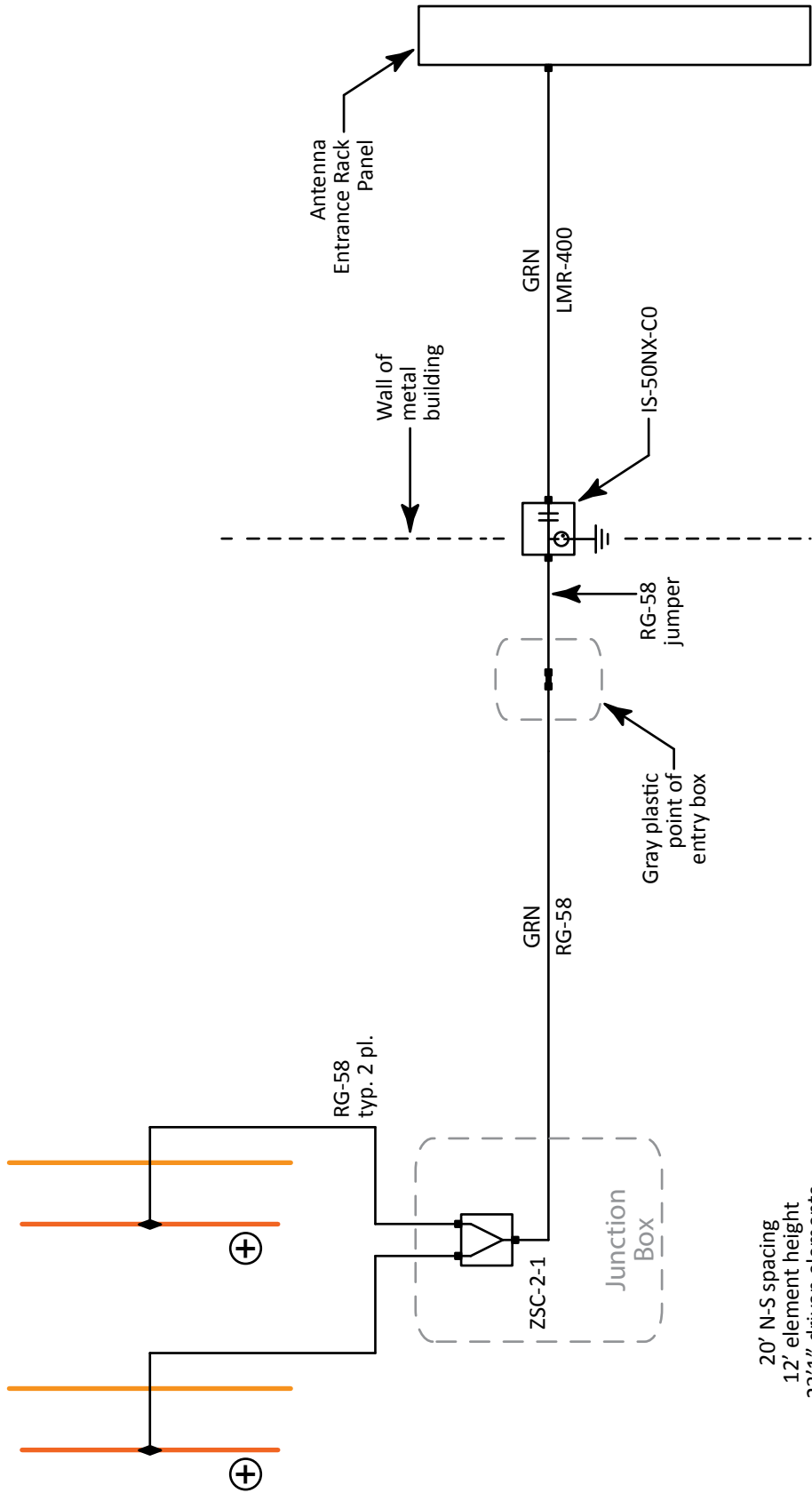

20' N-S spacing
 12' element height
 23'1" driven elements
 24'4" reflectors 7'6" below drivers

4	3	2	1
D	C	B	A

Riometer Array - Electrical

SIZE	DATE	PART NUMBER	REV
A	25 FEB 2017	N/A	A
SCALE	DRAWN BY	SHEET	1 OF 1
NONE	DAVE TYPINSKI	1	1

Riometer Array Feed System Losses

Feed line loss sweeps
performed 22 Jun 2017

Device sweeps performed
11 Aug 2013

Freq (MHz)	Rack panel to gray point of entry box		Gray box to J-box RG-58		J-box to element RG-58		Mini-Circuits ZSC-2-1 Combiner		Loss Between Element Feed Points and Entrance Panel (CAL PLANE) (dB)
	One Way Loss (dB)	One Way Loss (dB)	One Way Loss (dB)	One Way Loss (dB)	One Way Loss (dB)	One Way Loss (dB)	Loss (dB)		
16	-1.00	-1.09	-1.09	-0.61	-0.20	-2.9			
18	-1.06	-1.15	-1.15	-0.66	-0.21	-3.1			
20	-1.11	-1.23	-1.23	-0.69	-0.21	-3.2			
22	-1.17	-1.29	-1.29	-0.73	-0.22	-3.4			
24	-1.21	-1.35	-1.35	-0.77	-0.22	-3.6			
26	-1.26	-1.42	-1.42	-0.80	-0.23	-3.7			
28	-1.30	-1.47	-1.47	-0.85	-0.24	-3.9			
30	-1.35	-1.53	-1.53	-0.88	-0.24	-4.0			
32	-1.39	-1.59	-1.59	-0.91	-0.25	-4.1			



Riometer Array Feed Losses

SIZE A	DATE 22 JUN 2017	PART NUMBER N/A	REV A
SCALE NONE	DRAWN BY DAVE TYPINSKI	SHEET 1 OF 1	

1

2

3

4

D

C

B

A

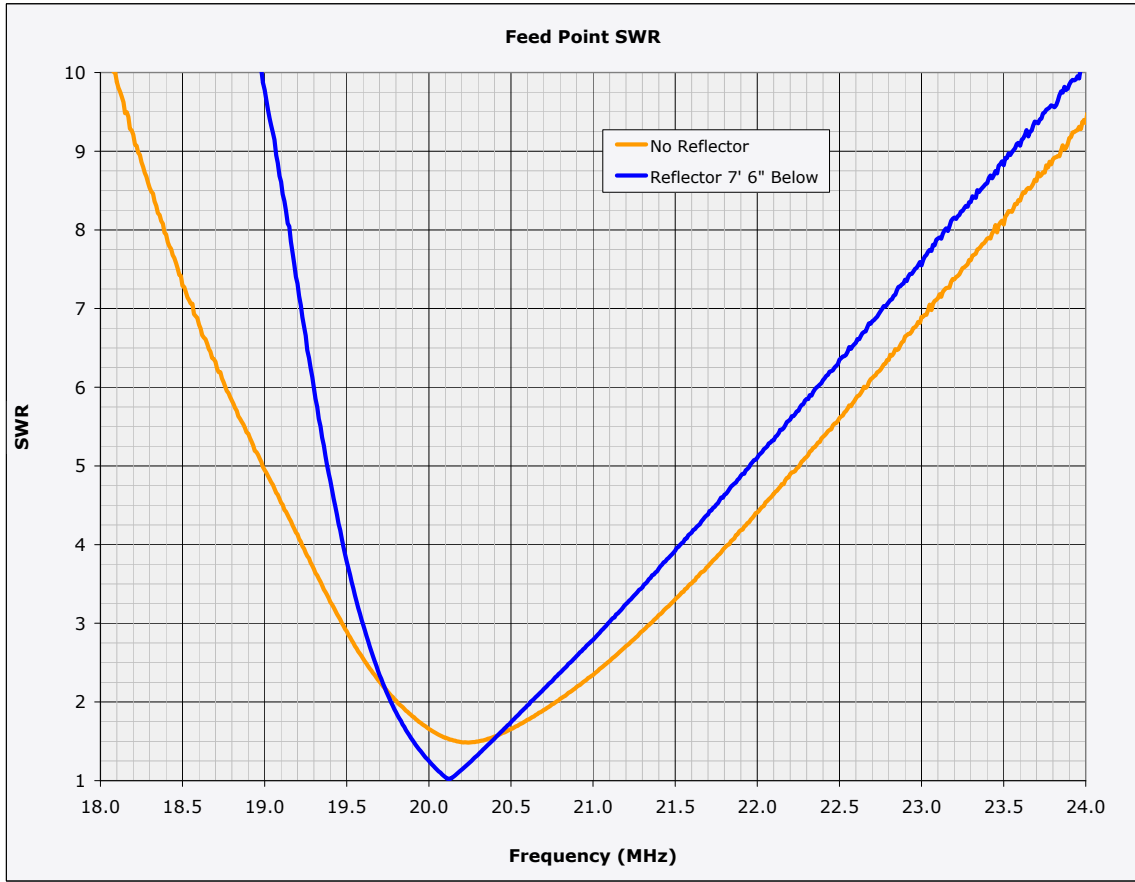
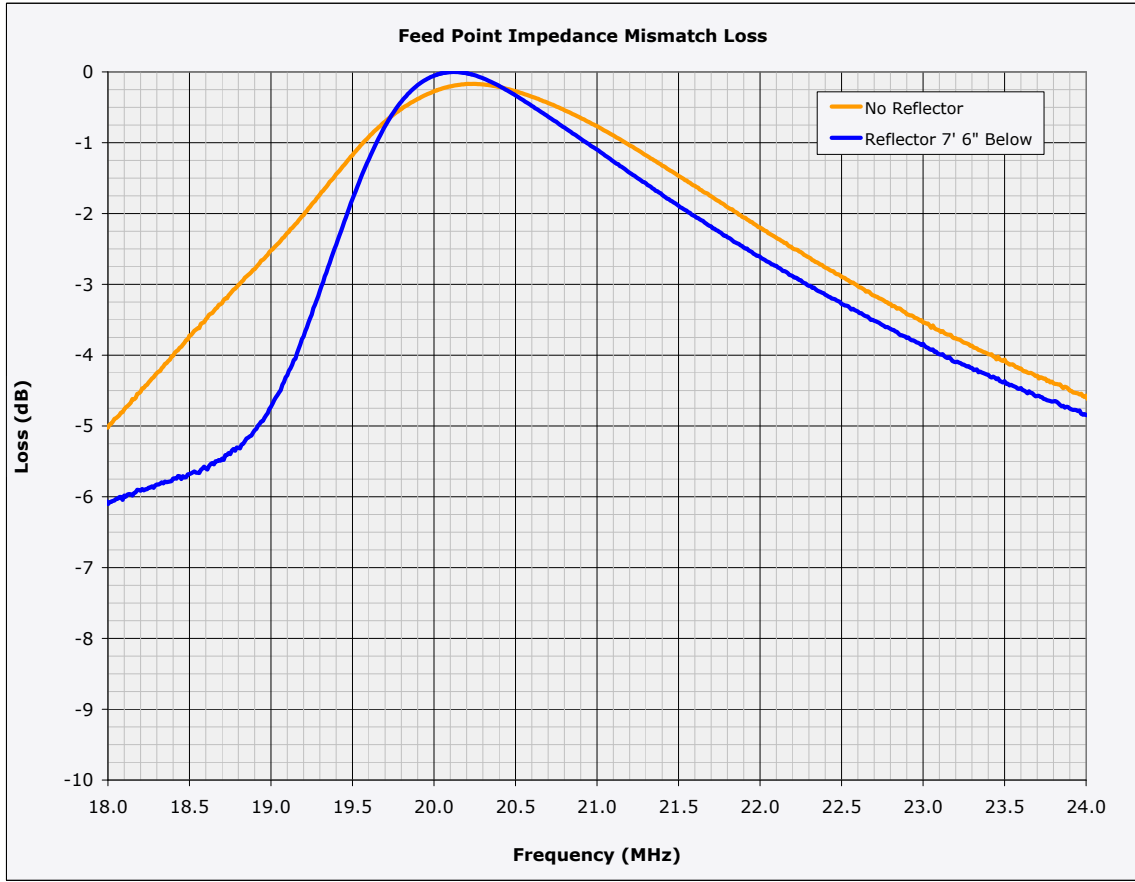

Riometer Array Element Sweeps



SIZE	DATE	PART NUMBER	REV
A	04 FEB 2017	N/A	A
SCALE	NONE	DRAWN BY	SHEET
		DAVE TYPINSKI	1 OF 2

Element sweeps performed with a VNA-2180.

A

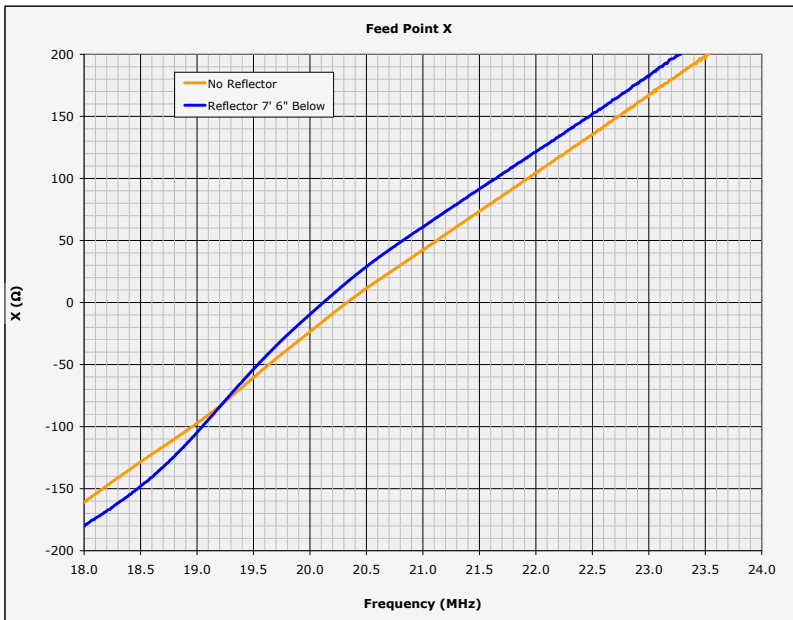
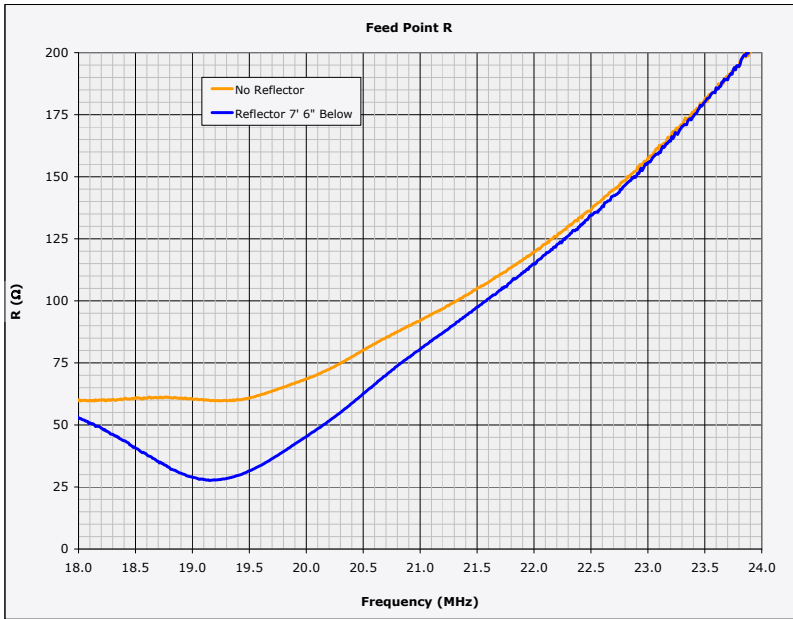
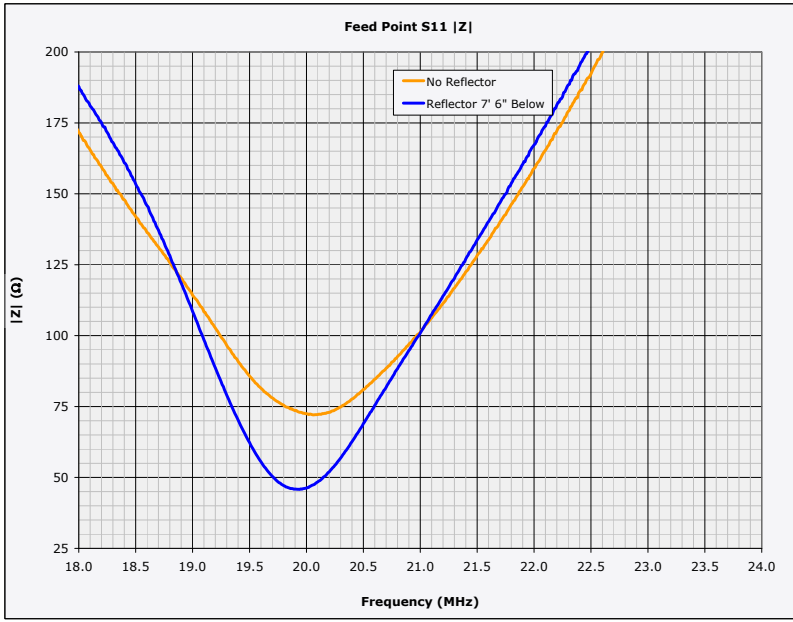

Element sweeps performed with a VNA-2180.

Riometer Array Element Sweeps



SIZE	DATE	PART NUMBER	REV
A	04 FEB 2017	N/A	A
SCALE	NONE	DRAWN BY	SHEET
		DAVE TYPINSKI	2 OF 2

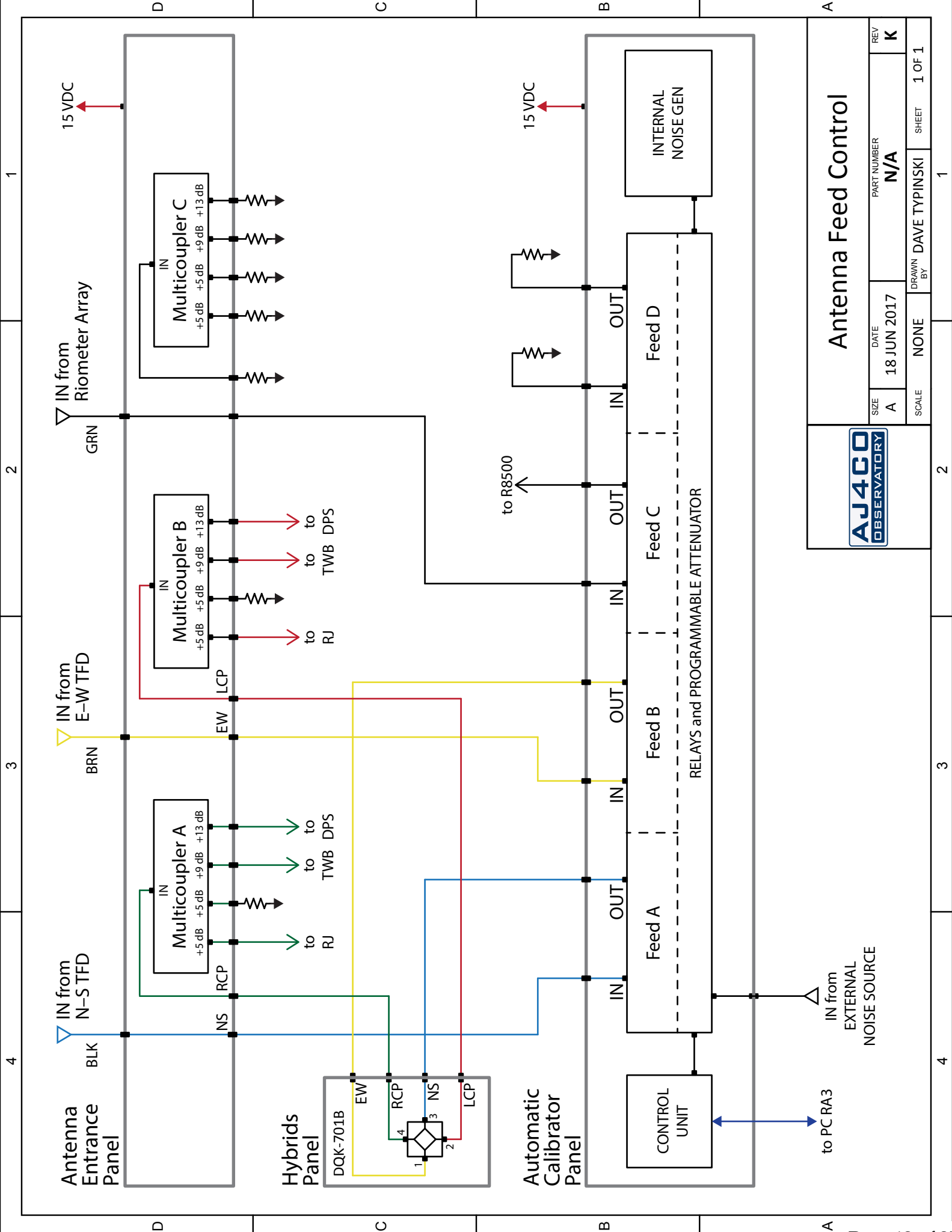

Antenna Feed Control		SIZE	DATE	PART NUMBER	REV
		A	18 JUN 2017	N/A	K
SCALE	DRAWN BY	SHEET	1 OF 1		
NONE	DAVE TYPINSKI	1			

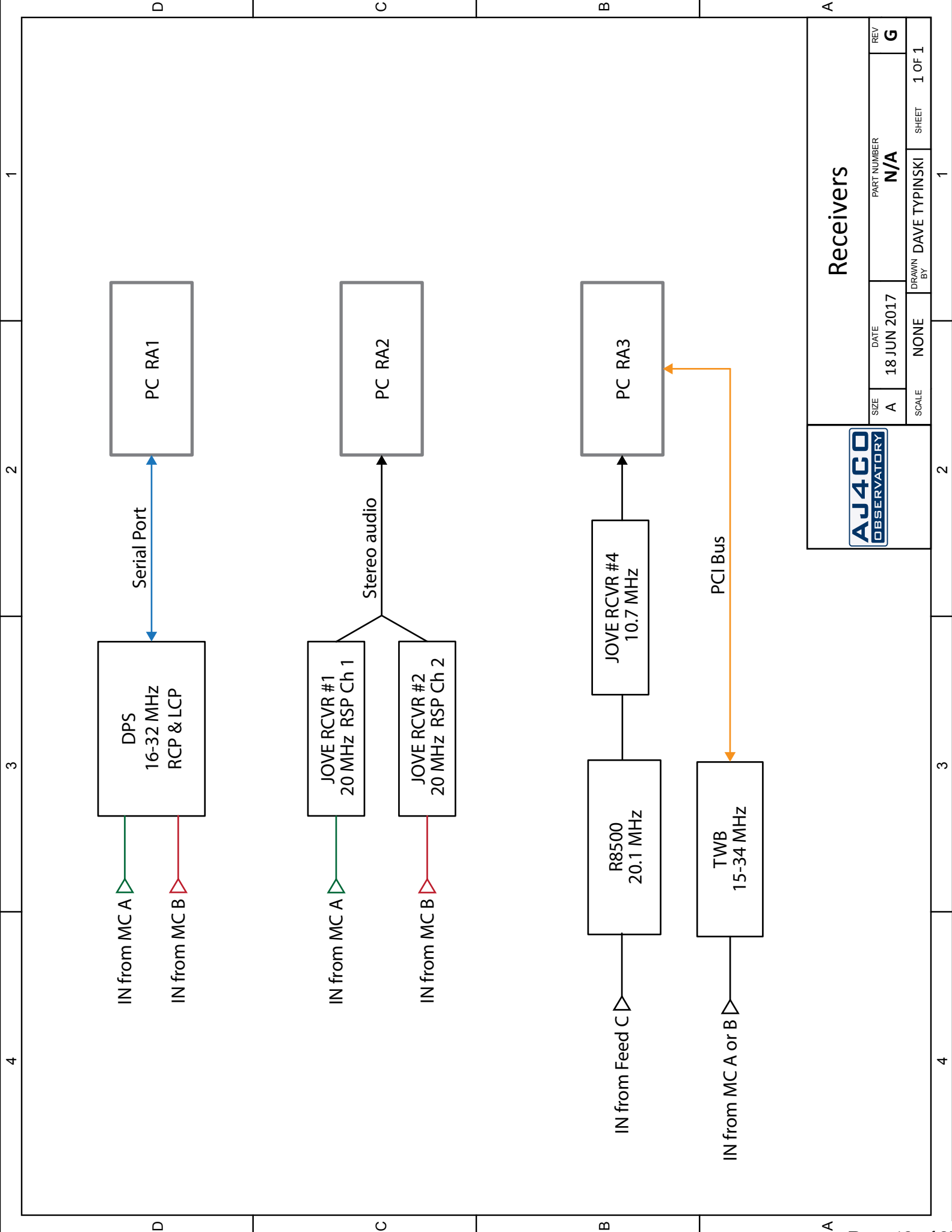

		DATE	18 JUN 2017	PART NUMBER	N/A	REV	G
		SCALE	NONE	DRAWN BY	DAVE TYPINSKI	SHEET	1 OF 1

Receivers

**Automatic Calibrator Temperatures
DPS on TFD Array**

T₀ (K) 290

Noise Source Temperature (MK) 440

Splitter Loss @ 20 MHz (dB) 6.2

Antenna Feed Loss @ 20 MHz (dB) 4.3

DPS Noise Figure @ 20 MHz (dB) 3.4 = 344 K @ HYBRID INPUTS

Calibration Plane: CAL relays between Antenna Feeds Entrance and Hybrid Ring Inputs.

Nom. Att. (dB)	Meas. Att. (dB)	Observed Temp. (K)	Equivalent Antenna Temp. (K)	Nom. Att. (dB)	Meas. Att. (dB)	Observed Temp. (K)	Equivalent Antenna Temp. (K)
0	0.56	92.8 MK	250 MK	0	0.56	92.8 MK	250 MK
1	1.52	74.4 MK	200 MK	3	3.43	47.9 MK	129 MK
2	2.56	58.5 MK	158 MK	6	6.47	23.8 MK	64.0 MK
4	4.57	36.9 MK	99.2 MK	9	9.45	12.0 MK	32.2 MK
8	8.55	14.7 MK	39.7 MK	12	12.58	5.83 MK	15.7 MK
16	16.58	2.32 MK	6.24 MK	15	15.48	2.99 MK	8.04 MK
32	32.50	60.0 kK	160 kK	18	18.55	1.47 MK	3.97 MK
64	64.65	671 K	387 K	21	21.50	748 kK	2.01 MK
				24	24.55	371 kK	997 kK
				27	27.51	188 kK	504 kK
				30	30.58	93.0 kK	249 kK
				33	33.49	47.9 kK	127 kK
				36	36.54	24.0 kK	63.3 kK
				39	39.55	12.3 kK	31.8 kK
				42	42.55	6.50 kK	16.1 kK
				45	45.59	3.55 kK	8.13 kK
				48	48.55	2.11 kK	4.26 kK



Calibration Temperatures

SIZE	DATE	PART NUMBER	REV
A	18 JUN 2017	N/A	B
SCALE	NONE	DRAWN BY	SHEET
		DAVE TYPINSKI	1 OF 2

**Automatic Calibrator Temperatures
R8500 + RJ on Riometer Array**

T₀ (K) 290

Noise Source Temperature (MK) 440

Splitter Loss @ 20 MHz (dB) 6.2

Antenna Feed Loss @ 20 MHz (dB) 3.2

R8500 Noise Figure @ 20 MHz (dB) 6.0 (this is a GUESS and is likely higher)

Calibration Plane: CAL relays between Antenna Feeds Entrance and R8500 Antenna Input.

Nom. Att. (dB)	Meas. Att. (dB)	Observed Temp. (K)	Equivalent Antenna Temp. (K)	Nom. Att. (dB)	Meas. Att. (dB)	Observed Temp. (K)	Equivalent Antenna Temp. (K)
0	0.56	92.8 MK	194 MK	0	0.56	92.8 MK	194 MK
1	1.52	74.4 MK	155 MK	3	3.43	47.9 MK	100 MK
2	2.56	58.5 MK	122 MK	6	6.47	23.8 MK	49.7 MK
4	4.57	36.9 MK	77.0 MK	9	9.45	12.0 MK	25.0 MK
8	8.55	14.7 MK	30.8 MK	12	12.58	5.83 MK	12.2 MK
16	16.58	2.32 MK	4.85 MK	15	15.48	2.99 MK	6.24 MK
32	32.50	60.5 kK	124 kK	18	18.55	1.48 MK	3.08 MK
64	64.65	1.19 kK	366 K	21	21.50	748 kK	1.56 MK
				24	24.55	371 kK	774 kK
				27	27.51	188 kK	392 kK
				30	30.58	93.5 kK	193 kK
				33	33.49	48.4 kK	99.0 kK
				36	36.54	24.6 kK	49.2 kK
				39	39.55	12.9 kK	24.7 kK
				42	42.55	7.02 kK	12.5 kK
				45	45.59	4.07 kK	6.38 kK
				48	48.55	2.63 kK	3.37 kK

Calibration Temperatures



SIZE	DATE	PART NUMBER	REV
A	18 JUN 2017	N/A	B
SCALE	NONE	DRAWN BY	SHEET
		DAVE TYPINSKI	2 OF 2

15 VDC Power Requirement

Equipment	Draw (mA)
Multicouplers	330
DPS Spectro	720
DPS IF Strips	570
Calibrator	980
TWB Rcvr	250
Jove Rcvrs	160
GPS-ntp-pi	120

Total: 3.1 Amps

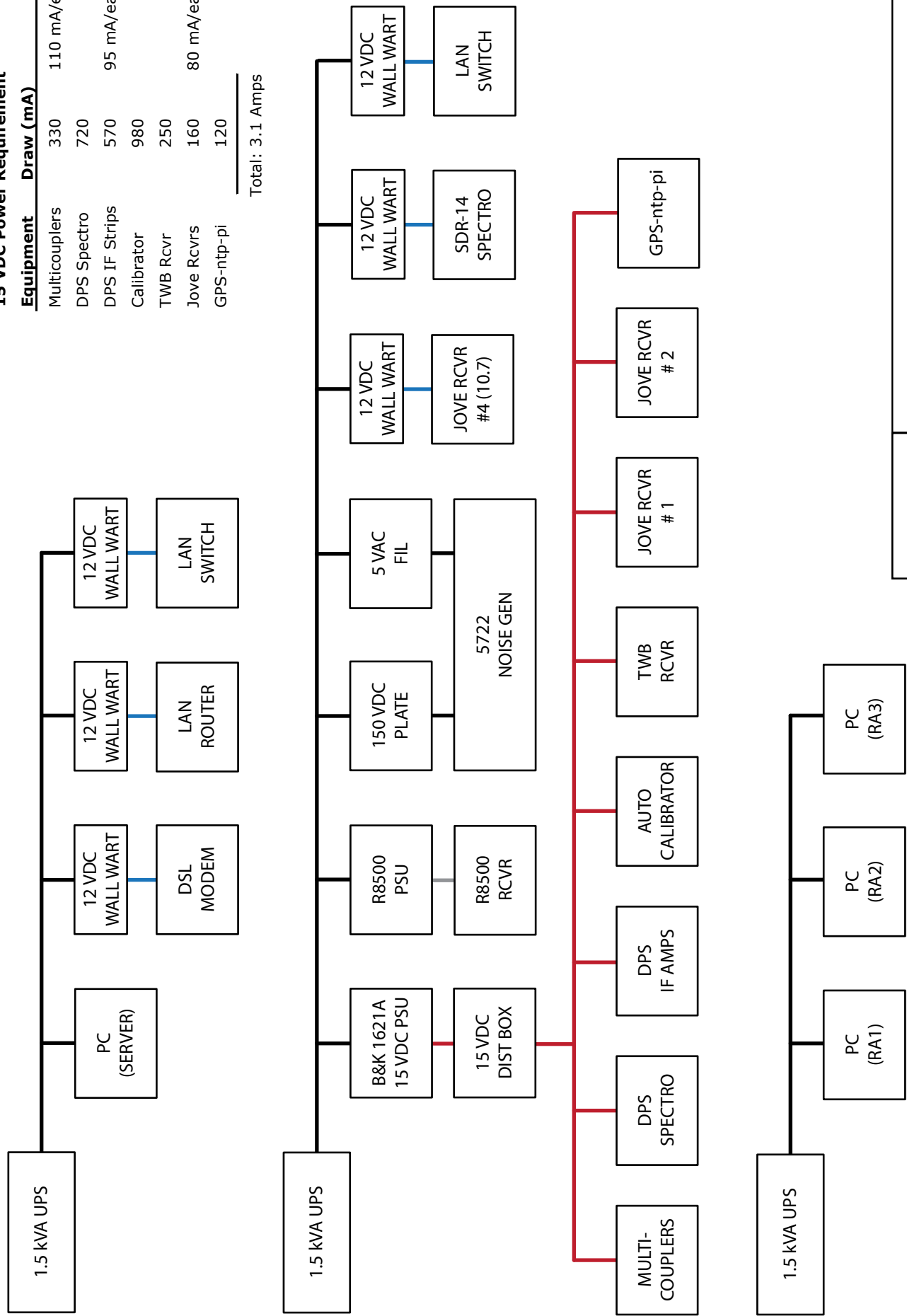

Power Distribution



SIZE	DATE	DRAWN BY	SHEET
A	18 JUN 2017	DAVE TYPINSKI	1 OF 1
SCALE	NONE		
REV	PART NUMBER		
B	N/A		

TFD Array Beam Steering

Time Delay Cable VoP: 66% ray elements N-S baseline spacing (feet): 32
 Array elements E-W baseline spacing (feet): 32

N-S Offset (degrees)	E-W Offset (degrees)	A (S) / B (N)	C (S) / D (N)	E	F (W) / G (E)	H	AZ (degrees)	EL (degrees)
20 N	60 E	7' 2-3/4"	14' 5-1/4"	3' 7-1/4"	18' 3-1/2"	9' 1-3/4"	78	29
20 N	45 E	7' 2-3/4"	14' 5-1/4"	3' 7-1/4"	14' 11-1/4"	7' 5-1/2"	70	43
20 N	30 E	7' 2-3/4"	14' 5-1/4"	3' 7-1/4"	10' 6-3/4"	5' 3-1/4"	58	56
20 N	15 E	7' 2-3/4"	14' 5-1/4"	3' 7-1/4"	5' 5-1/2"	2' 8-3/4"	36	66
20 N	0	7' 2-3/4"	14' 5-1/4"	3' 7-1/4"	0"	0"	0	70
20 N	15 W	7' 2-3/4"	14' 5-1/4"	3' 7-1/4"	5' 5-1/2"	2' 8-3/4"	324	66
20 N	30 W	7' 2-3/4"	14' 5-1/4"	3' 7-1/4"	10' 6-3/4"	5' 3-1/4"	302	56
20 N	45 W	7' 2-3/4"	14' 5-1/4"	3' 7-1/4"	14' 11-1/4"	7' 5-1/2"	290	43
20 N	60 W	7' 2-3/4"	14' 5-1/4"	3' 7-1/4"	18' 3-1/2"	9' 1-3/4"	282	29
15 N	60 E	5' 5-1/2"	10' 11-1/4"	2' 8-3/4"	18' 3-1/2"	9' 1-3/4"	81	30
15 N	45 E	5' 5-1/2"	10' 11-1/4"	2' 8-3/4"	14' 11-1/4"	7' 5-1/2"	75	44
15 N	30 E	5' 5-1/2"	10' 11-1/4"	2' 8-3/4"	10' 6-3/4"	5' 3-1/4"	65	58
15 N	15 E	5' 5-1/2"	10' 11-1/4"	2' 8-3/4"	5' 5-1/2"	2' 8-3/4"	45	69
15 N	0	5' 5-1/2"	10' 11-1/4"	2' 8-3/4"	0"	0"	360	75
15 N	15 W	5' 5-1/2"	10' 11-1/4"	2' 8-3/4"	5' 5-1/2"	2' 8-3/4"	315	69
15 N	30 W	5' 5-1/2"	10' 11-1/4"	2' 8-3/4"	10' 6-3/4"	5' 3-1/4"	295	58
15 N	45 W	5' 5-1/2"	10' 11-1/4"	2' 8-3/4"	14' 11-1/4"	7' 5-1/2"	285	44
15 N	60 W	5' 5-1/2"	10' 11-1/4"	2' 8-3/4"	18' 3-1/2"	9' 1-3/4"	279	30
10 N	60 E	3' 8"	7' 4"	1' 10"	18' 3-1/2"	9' 1-3/4"	84	30
10 N	45 E	3' 8"	7' 4"	1' 10"	14' 11-1/4"	7' 5-1/2"	80	45
10 N	30 E	3' 8"	7' 4"	1' 10"	10' 6-3/4"	5' 3-1/4"	73	59
10 N	15 E	3' 8"	7' 4"	1' 10"	5' 5-1/2"	2' 8-3/4"	57	72
10 N	0	3' 8"	7' 4"	1' 10"	0"	0"	360	80
10 N	15 W	3' 8"	7' 4"	1' 10"	5' 5-1/2"	2' 8-3/4"	303	72
10 N	30 W	3' 8"	7' 4"	1' 10"	10' 6-3/4"	5' 3-1/4"	287	59
10 N	45 W	3' 8"	7' 4"	1' 10"	14' 11-1/4"	7' 5-1/2"	280	45
10 N	60 W	3' 8"	7' 4"	1' 10"	18' 3-1/2"	9' 1-3/4"	276	30

TFD Array Beam Steering

SIZE: A DATE: 01 OCT 2014 PART NUMBER: N/A REV: A
 SCALE: NONE DRAWN BY: DAVE TYPINSKI SHEET: 1 OF 6

TFD Array Beam Steering

Time Delay Cable VoP: 66% **Array elements N-S baseline spacing (feet):** 32
Array elements E-W baseline spacing (feet): 32

N-S Offset (degrees)	E-W Offset (degrees)	Delay Cable Lengths (feet & inches)					AZ (degrees)	EL (degrees)
		A (S) / B (N)	C (S) / D (N)	E	F (W) / G (E)	H		
5 N	60 E	1' 10"	3' 8-1/4"	11"	18' 3-1/2"	9' 1-3/4"	87	30
5 N	45 E	1' 10"	3' 8-1/4"	11"	14' 11-1/4"	7' 5-1/2"	85	45
5 N	30 E	1' 10"	3' 8-1/4"	11"	10' 6-3/4"	5' 3-1/4"	81	60
5 N	15 E	1' 10"	3' 8-1/4"	11"	5' 5-1/2"	2' 8-3/4"	72	74
5 N	0	1' 10"	3' 8-1/4"	11"	0"	0"	360	85
5 N	15 W	1' 10"	3' 8-1/4"	11"	5' 5-1/2"	2' 8-3/4"	288	74
5 N	30 W	1' 10"	3' 8-1/4"	11"	10' 6-3/4"	5' 3-1/4"	279	60
5 N	45 W	1' 10"	3' 8-1/4"	11"	14' 11-1/4"	7' 5-1/2"	275	45
5 N	60 W	1' 10"	3' 8-1/4"	11"	18' 3-1/2"	9' 1-3/4"	273	30
0	60 E	0"	0"	0"	18' 3-1/2"	9' 1-3/4"	90	30
0	45 E	0"	0"	0"	14' 11-1/4"	7' 5-1/2"	90	45
0	30 E	0"	0"	0"	10' 6-3/4"	5' 3-1/4"	90	60
0	15 E	0"	0"	0"	5' 5-1/2"	2' 8-3/4"	90	75
0	0	0"	0"	0"	0"	0"	180	90
0	15 W	0"	0"	0"	5' 5-1/2"	2' 8-3/4"	270	75
0	30 W	0"	0"	0"	10' 6-3/4"	5' 3-1/4"	270	60
0	45 W	0"	0"	0"	14' 11-1/4"	7' 5-1/2"	270	45
0	60 W	0"	0"	0"	18' 3-1/2"	9' 1-3/4"	270	30
5 S	60 E	1' 10"	3' 8-1/4"	11"	18' 3-1/2"	9' 1-3/4"	93	30
5 S	45 E	1' 10"	3' 8-1/4"	11"	14' 11-1/4"	7' 5-1/2"	95	45
5 S	30 E	1' 10"	3' 8-1/4"	11"	10' 6-3/4"	5' 3-1/4"	99	60
5 S	15 E	1' 10"	3' 8-1/4"	11"	5' 5-1/2"	2' 8-3/4"	108	74
5 S	0	1' 10"	3' 8-1/4"	11"	0"	0"	180	85
5 S	15 W	1' 10"	3' 8-1/4"	11"	5' 5-1/2"	2' 8-3/4"	252	74
5 S	30 W	1' 10"	3' 8-1/4"	11"	10' 6-3/4"	5' 3-1/4"	261	60
5 S	45 W	1' 10"	3' 8-1/4"	11"	14' 11-1/4"	7' 5-1/2"	265	45
5 S	60 W	1' 10"	3' 8-1/4"	11"	18' 3-1/2"	9' 1-3/4"	267	30

TFD Array Beam Steering

SIZE	A	DATE	01 OCT 2014	PART NUMBER	N/A	REV	A
SCALE	NONE	DRAWN BY	DAVE TYPINSKI	SHEET	2 OF 6		

TFD Array Beam Steering

Time Delay Cable VoP: 66% **Array elements N-S baseline spacing (feet):** 32
Array elements E-W baseline spacing (feet): 32

N-S Offset (degrees)	E-W Offset (degrees)	Delay Cable Lengths (feet & inches)					AZ (degrees)	EL (degrees)
		A (S) / B (N)	C (S) / D (N)	E	F (W) / G (E)	H		
10 S	60 E	3' 8"	7' 4"	1' 10"	18' 3-1/2"	9' 1-3/4"	96	30
10 S	45 E	3' 8"	7' 4"	1' 10"	14' 11-1/4"	7' 5-1/2"	100	45
10 S	30 E	3' 8"	7' 4"	1' 10"	10' 6-3/4"	5' 3-1/4"	107	59
10 S	15 E	3' 8"	7' 4"	1' 10"	5' 5-1/2"	2' 8-3/4"	123	72
10 S	0	3' 8"	7' 4"	1' 10"	0"	0"	180	80
10 S	15 W	3' 8"	7' 4"	1' 10"	5' 5-1/2"	2' 8-3/4"	237	72
10 S	30 W	3' 8"	7' 4"	1' 10"	10' 6-3/4"	5' 3-1/4"	253	59
10 S	45 W	3' 8"	7' 4"	1' 10"	14' 11-1/4"	7' 5-1/2"	260	45
10 S	60 W	3' 8"	7' 4"	1' 10"	18' 3-1/2"	9' 1-3/4"	264	30
15 S	60 E	5' 5-1/2"	10' 11-1/4"	2' 8-3/4"	18' 3-1/2"	9' 1-3/4"	99	30
15 S	45 E	5' 5-1/2"	10' 11-1/4"	2' 8-3/4"	14' 11-1/4"	7' 5-1/2"	105	44
15 S	30 E	5' 5-1/2"	10' 11-1/4"	2' 8-3/4"	10' 6-3/4"	5' 3-1/4"	115	58
15 S	15 E	5' 5-1/2"	10' 11-1/4"	2' 8-3/4"	5' 5-1/2"	2' 8-3/4"	135	69
15 S	0	5' 5-1/2"	10' 11-1/4"	2' 8-3/4"	0"	0"	180	75
15 S	15 W	5' 5-1/2"	10' 11-1/4"	2' 8-3/4"	5' 5-1/2"	2' 8-3/4"	225	69
15 S	30 W	5' 5-1/2"	10' 11-1/4"	2' 8-3/4"	10' 6-3/4"	5' 3-1/4"	245	58
15 S	45 W	5' 5-1/2"	10' 11-1/4"	2' 8-3/4"	14' 11-1/4"	7' 5-1/2"	255	44
15 S	60 W	5' 5-1/2"	10' 11-1/4"	2' 8-3/4"	18' 3-1/2"	9' 1-3/4"	261	30
20 S	60 E	7' 2-3/4"	14' 5-1/4"	3' 7-1/4"	18' 3-1/2"	9' 1-3/4"	102	29
20 S	45 E	7' 2-3/4"	14' 5-1/4"	3' 7-1/4"	14' 11-1/4"	7' 5-1/2"	110	43
20 S	30 E	7' 2-3/4"	14' 5-1/4"	3' 7-1/4"	10' 6-3/4"	5' 3-1/4"	122	56
20 S	15 E	7' 2-3/4"	14' 5-1/4"	3' 7-1/4"	5' 5-1/2"	2' 8-3/4"	144	66
20 S	0	7' 2-3/4"	14' 5-1/4"	3' 7-1/4"	0"	0"	180	70
20 S	15 W	7' 2-3/4"	14' 5-1/4"	3' 7-1/4"	5' 5-1/2"	2' 8-3/4"	216	66
20 S	30 W	7' 2-3/4"	14' 5-1/4"	3' 7-1/4"	10' 6-3/4"	5' 3-1/4"	238	56
20 S	45 W	7' 2-3/4"	14' 5-1/4"	3' 7-1/4"	14' 11-1/4"	7' 5-1/2"	250	43
20 S	60 W	7' 2-3/4"	14' 5-1/4"	3' 7-1/4"	18' 3-1/2"	9' 1-3/4"	258	29



TFD Array Beam Steering

SCALE: NONE

DRAWN BY: DAVE TYPINSKI

SHEET: 3 OF 6

TFD Array Beam Steering

Time Delay Cable VoP: 66% **Array elements N-S baseline spacing (feet):** 32
Array elements E-W baseline spacing (feet): 32

N-S Offset (degrees)	E-W Offset (degrees)	A (S) / B (N) C (S) / D (N)	Delay Cable Lengths (feet & inches)		F (W) / G (E)	H	AZ (degrees)	EL (degrees)
25 S	60 E	8' 11"	17' 10-1/4"	4' 5-1/2"	18' 3-1/2"	9' 1-3/4"	105	29
25 S	45 E	8' 11"	17' 10-1/4"	4' 5-1/2"	14' 11-1/4"	7' 5-1/2"	115	42
25 S	30 E	8' 11"	17' 10-1/4"	4' 5-1/2"	10' 6-3/4"	5' 3-1/4"	129	53
25 S	15 E	8' 11"	17' 10-1/4"	4' 5-1/2"	5' 5-1/2"	2' 8-3/4"	150	62
25 S	0	8' 11"	17' 10-1/4"	4' 5-1/2"	0"	0"	180	65
25 S	15 W	8' 11"	17' 10-1/4"	4' 5-1/2"	5' 5-1/2"	2' 8-3/4"	210	62
25 S	30 W	8' 11"	17' 10-1/4"	4' 5-1/2"	10' 6-3/4"	5' 3-1/4"	231	53
25 S	45 W	8' 11"	17' 10-1/4"	4' 5-1/2"	14' 11-1/4"	7' 5-1/2"	245	42
25 S	60 W	8' 11"	17' 10-1/4"	4' 5-1/2"	18' 3-1/2"	9' 1-3/4"	255	29
30 S	60 E	10' 6-3/4"	21' 1-1/2"	5' 3-1/4"	18' 3-1/2"	9' 1-3/4"	108	29
30 S	45 E	10' 6-3/4"	21' 1-1/2"	5' 3-1/4"	14' 11-1/4"	7' 5-1/2"	120	41
30 S	30 E	10' 6-3/4"	21' 1-1/2"	5' 3-1/4"	10' 6-3/4"	5' 3-1/4"	135	51
30 S	15 E	10' 6-3/4"	21' 1-1/2"	5' 3-1/4"	5' 5-1/2"	2' 8-3/4"	155	58
30 S	0	10' 6-3/4"	21' 1-1/2"	5' 3-1/4"	0"	0"	180	60
30 S	15 W	10' 6-3/4"	21' 1-1/2"	5' 3-1/4"	5' 5-1/2"	2' 8-3/4"	205	58
30 S	30 W	10' 6-3/4"	21' 1-1/2"	5' 3-1/4"	10' 6-3/4"	5' 3-1/4"	225	51
30 S	45 W	10' 6-3/4"	21' 1-1/2"	5' 3-1/4"	14' 11-1/4"	7' 5-1/2"	240	41
30 S	60 W	10' 6-3/4"	21' 1-1/2"	5' 3-1/4"	18' 3-1/2"	9' 1-3/4"	252	29
35 S	60 E	12' 1-1/4"	24' 2-3/4"	6' 0-3/4"	18' 3-1/2"	9' 1-3/4"	112	28
35 S	45 E	12' 1-1/4"	24' 2-3/4"	6' 0-3/4"	14' 11-1/4"	7' 5-1/2"	125	39
35 S	30 E	12' 1-1/4"	24' 2-3/4"	6' 0-3/4"	10' 6-3/4"	5' 3-1/4"	140	48
35 S	15 E	12' 1-1/4"	24' 2-3/4"	6' 0-3/4"	5' 5-1/2"	2' 8-3/4"	159	53
35 S	0	12' 1-1/4"	24' 2-3/4"	6' 0-3/4"	0"	0"	180	55
35 S	15 W	12' 1-1/4"	24' 2-3/4"	6' 0-3/4"	5' 5-1/2"	2' 8-3/4"	201	53
35 S	30 W	12' 1-1/4"	24' 2-3/4"	6' 0-3/4"	10' 6-3/4"	5' 3-1/4"	220	48
35 S	45 W	12' 1-1/4"	24' 2-3/4"	6' 0-3/4"	14' 11-1/4"	7' 5-1/2"	235	39
35 S	60 W	12' 1-1/4"	24' 2-3/4"	6' 0-3/4"	18' 3-1/2"	9' 1-3/4"	248	28



TFD Array Beam Steering

SIZE	DATE	PART NUMBER	REV
A	01 OCT 2014	N/A	A
SCALE	NONE	DRAWN BY	SHEET
		DAVE TYPINSKI	4 OF 6

TFD Array Beam Steering

Time Delay Cable VoP: 66% **Array elements N-S baseline spacing (feet):** 32
Array elements E-W baseline spacing (feet): 32

N-S Offset (degrees)	E-W Offset (degrees)	Delay Cable Lengths (feet & inches)				AZ (degrees)	EL (degrees)	
		A (S) / B (N)	C (S) / D (N)	E	F (W) / G (E)			H
40 S	60 E	13' 7"	27' 1-3/4"	6' 9-1/2"	18' 3-1/2"	9' 1-3/4"	116	27
40 S	45 E	13' 7"	27' 1-3/4"	6' 9-1/2"	14' 11-1/4"	7' 5-1/2"	130	37
40 S	30 E	13' 7"	27' 1-3/4"	6' 9-1/2"	10' 6-3/4"	5' 3-1/4"	145	44
40 S	15 E	13' 7"	27' 1-3/4"	6' 9-1/2"	5' 5-1/2"	2' 8-3/4"	162	49
40 S	0	13' 7"	27' 1-3/4"	6' 9-1/2"	0"	0"	180	50
40 S	15 W	13' 7"	27' 1-3/4"	6' 9-1/2"	5' 5-1/2"	2' 8-3/4"	198	49
40 S	30 W	13' 7"	27' 1-3/4"	6' 9-1/2"	10' 6-3/4"	5' 3-1/4"	215	44
40 S	45 W	13' 7"	27' 1-3/4"	6' 9-1/2"	14' 11-1/4"	7' 5-1/2"	230	37
40 S	60 W	13' 7"	27' 1-3/4"	6' 9-1/2"	18' 3-1/2"	9' 1-3/4"	244	27
45 S	60 E	14' 11-1/4"	29' 10-1/2"	7' 5-1/2"	18' 3-1/2"	9' 1-3/4"	120	27
45 S	45 E	14' 11-1/4"	29' 10-1/2"	7' 5-1/2"	14' 11-1/4"	7' 5-1/2"	135	35
45 S	30 E	14' 11-1/4"	29' 10-1/2"	7' 5-1/2"	10' 6-3/4"	5' 3-1/4"	150	41
45 S	15 E	14' 11-1/4"	29' 10-1/2"	7' 5-1/2"	5' 5-1/2"	2' 8-3/4"	165	44
45 S	0	14' 11-1/4"	29' 10-1/2"	7' 5-1/2"	0"	0"	180	45
45 S	15 W	14' 11-1/4"	29' 10-1/2"	7' 5-1/2"	5' 5-1/2"	2' 8-3/4"	195	44
45 S	30 W	14' 11-1/4"	29' 10-1/2"	7' 5-1/2"	10' 6-3/4"	5' 3-1/4"	210	41
45 S	45 W	14' 11-1/4"	29' 10-1/2"	7' 5-1/2"	14' 11-1/4"	7' 5-1/2"	225	35
45 S	60 W	14' 11-1/4"	29' 10-1/2"	7' 5-1/2"	18' 3-1/2"	9' 1-3/4"	240	27
50 S	60 E	16' 2-1/4"	32' 4-1/4"	8' 1"	18' 3-1/2"	9' 1-3/4"	125	25
50 S	45 E	16' 2-1/4"	32' 4-1/4"	8' 1"	14' 11-1/4"	7' 5-1/2"	140	33
50 S	30 E	16' 2-1/4"	32' 4-1/4"	8' 1"	10' 6-3/4"	5' 3-1/4"	154	37
50 S	15 E	16' 2-1/4"	32' 4-1/4"	8' 1"	5' 5-1/2"	2' 8-3/4"	167	39
50 S	0	16' 2-1/4"	32' 4-1/4"	8' 1"	0"	0"	180	40
50 S	15 W	16' 2-1/4"	32' 4-1/4"	8' 1"	5' 5-1/2"	2' 8-3/4"	193	39
50 S	30 W	16' 2-1/4"	32' 4-1/4"	8' 1"	10' 6-3/4"	5' 3-1/4"	206	37
50 S	45 W	16' 2-1/4"	32' 4-1/4"	8' 1"	14' 11-1/4"	7' 5-1/2"	220	33
50 S	60 W	16' 2-1/4"	32' 4-1/4"	8' 1"	18' 3-1/2"	9' 1-3/4"	235	25

TFD Array Beam Steering

DATE: 01 OCT 2014

SCALE: NONE

DRAWN BY: DAVE TYPINSKI

PART NUMBER: N/A

SHEET: 5 OF 6

TFD Array Beam Steering

Time Delay Cable VoP: 66% **Array elements N-S baseline spacing (feet): 32**
Array elements E-W baseline spacing (feet): 32

N-S Offset (degrees)	E-W Offset (degrees)	Delay Cable Lengths (feet & inches)				AZ (degrees)	EL (degrees)	
		A (S) / B (N)	C (S) / D (N)	E F (W) / G (E)	H			
55 S	60 E	17' 3-1/2"	34' 7-1/4"	8' 7-3/4"	18' 3-1/2"	9' 1-3/4"	130	24
55 S	45 E	17' 3-1/2"	34' 7-1/4"	8' 7-3/4"	14' 11-1/4"	7' 5-1/2"	145	30
55 S	30 E	17' 3-1/2"	34' 7-1/4"	8' 7-3/4"	10' 6-3/4"	5' 3-1/4"	158	33
55 S	15 E	17' 3-1/2"	34' 7-1/4"	8' 7-3/4"	5' 5-1/2"	2' 8-3/4"	169	35
55 S	0	17' 3-1/2"	34' 7-1/4"	8' 7-3/4"	0"	0"	180	35
55 S	15 W	17' 3-1/2"	34' 7-1/4"	8' 7-3/4"	5' 5-1/2"	2' 8-3/4"	191	35
55 S	30 W	17' 3-1/2"	34' 7-1/4"	8' 7-3/4"	10' 6-3/4"	5' 3-1/4"	202	33
55 S	45 W	17' 3-1/2"	34' 7-1/4"	8' 7-3/4"	14' 11-1/4"	7' 5-1/2"	215	30
55 S	60 W	17' 3-1/2"	34' 7-1/4"	8' 7-3/4"	18' 3-1/2"	9' 1-3/4"	230	24
60 S	60 E	18' 3-1/2"	36' 7"	9' 1-3/4"	18' 3-1/2"	9' 1-3/4"	135	22
60 S	45 E	18' 3-1/2"	36' 7"	9' 1-3/4"	14' 11-1/4"	7' 5-1/2"	150	27
60 S	30 E	18' 3-1/2"	36' 7"	9' 1-3/4"	10' 6-3/4"	5' 3-1/4"	162	29
60 S	15 E	18' 3-1/2"	36' 7"	9' 1-3/4"	5' 5-1/2"	2' 8-3/4"	171	30
60 S	0	18' 3-1/2"	36' 7"	9' 1-3/4"	0"	0"	180	30
60 S	15 W	18' 3-1/2"	36' 7"	9' 1-3/4"	5' 5-1/2"	2' 8-3/4"	189	30
60 S	30 W	18' 3-1/2"	36' 7"	9' 1-3/4"	10' 6-3/4"	5' 3-1/4"	198	29
60 S	45 W	18' 3-1/2"	36' 7"	9' 1-3/4"	14' 11-1/4"	7' 5-1/2"	210	27
60 S	60 W	18' 3-1/2"	36' 7"	9' 1-3/4"	18' 3-1/2"	9' 1-3/4"	225	22



TFD Array Beam Steering

SIZE A	DATE 01 OCT 2014	PART NUMBER N/A	REV A
SCALE NONE	DRAWN BY DAVE TYPINSKI	SHEET 6 OF 6	

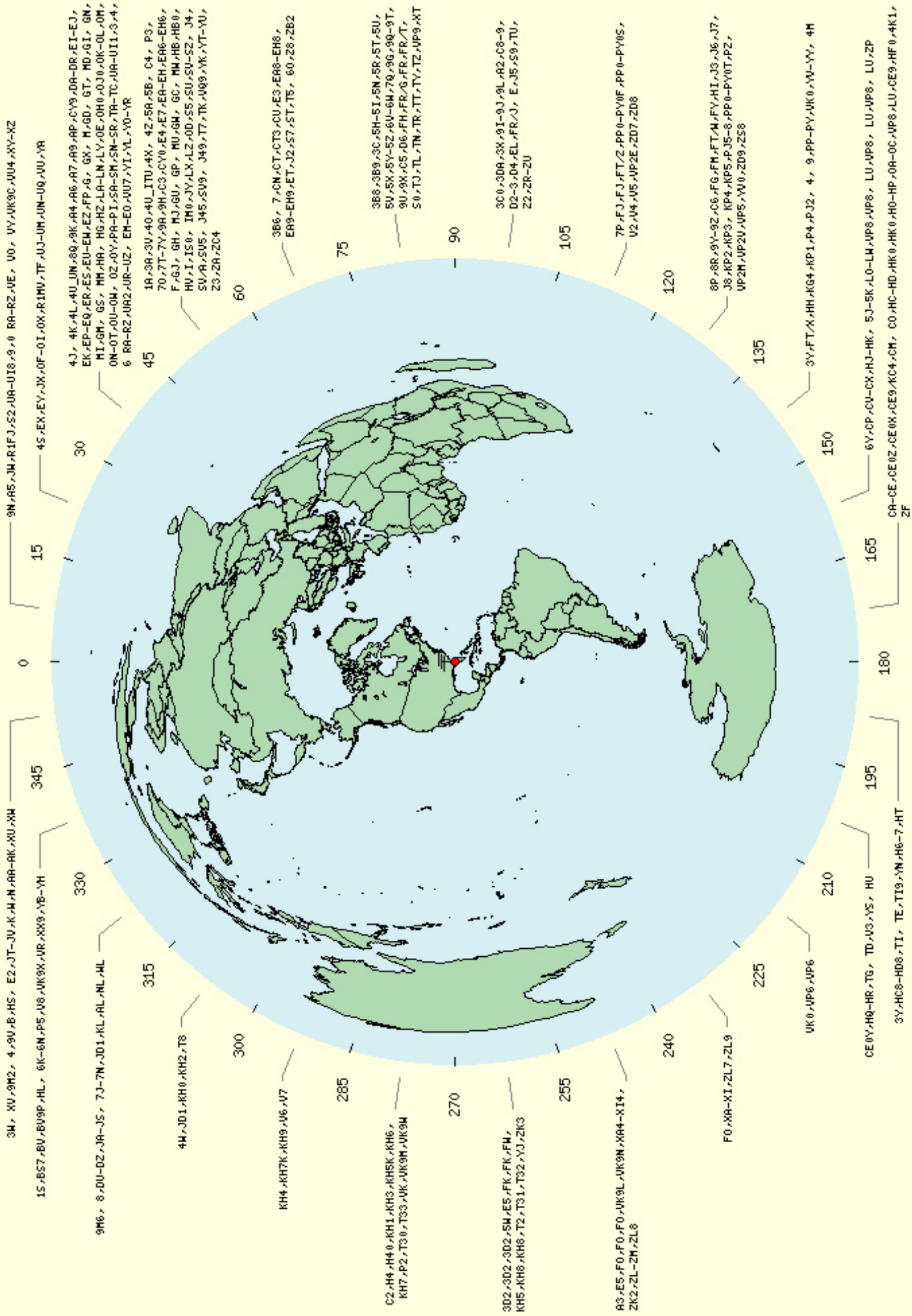



Find the magnetic declination at your location

Find your location or click on the map to display your magnetic declination

[Browse countries](#) [What is Magnetic Declination?](#)

Sites of Interest

- [Real Time Cinema](#)
- [Satellite tracking](#)
- [Radio Astronomy](#)

Find your location

high springs

USA

FLORIDA

SEARCH MAP

[Browse countries](#)

1 HIGH SPRINGS FL

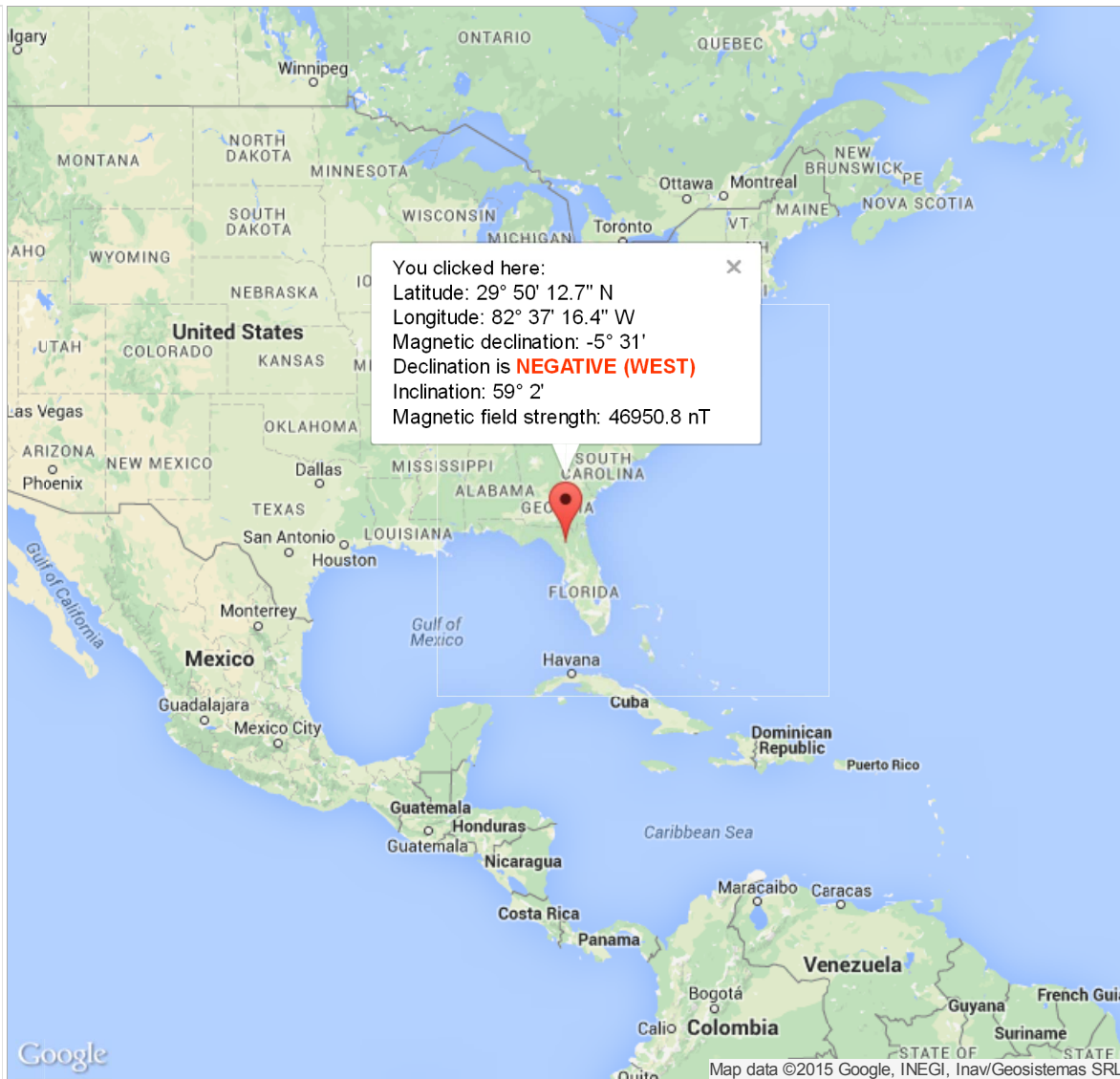

Copyright ©2015 Magnetic-Declination.com
 Questions? webmaster@magnetic-declination.com

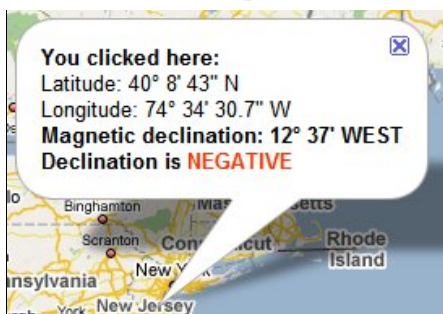
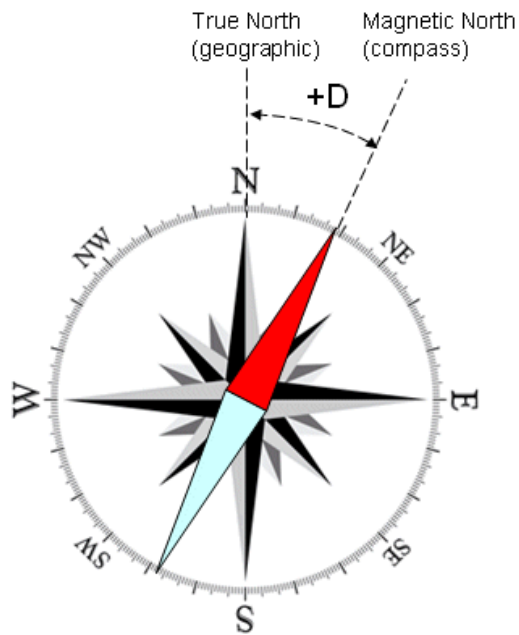
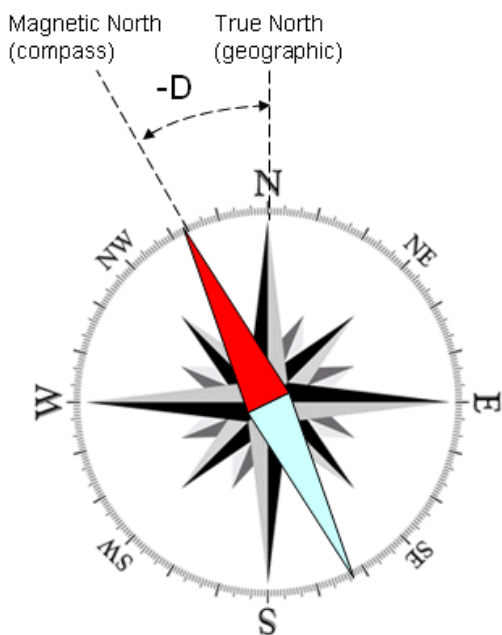

Negative declination (WEST)

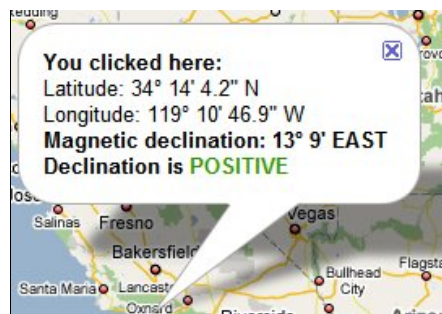

Positive declination (EAST)

How can we calculate declination at any given place?

One way would be to use declination maps. Unfortunately because of secular variation, declination values are constantly changing. When printed maps were the only way of getting this information, the declination values were somewhat out of date by the time the maps got to the general public.

Another way would be to perform a prediction. This should be based on a world-wide empirical model of the deep flows. This [web page](#) operated by the National Geophysical Data Center (NDGC) offers a pretty good value for declination. The model reflects a highly predictable rate of change, and will usually be more accurate than a map, and almost never less accurate.

The best way however is to use [the current web site](#), which offers in a graphical format using Google Maps API the computed declination for any place on Earth. The algorithm implements the [World Magnetic Model WMM2015](#).



Copyright ©2015 [Magnetic-Declination.com](#)
 Questions? webmaster@magnetic-declination.com

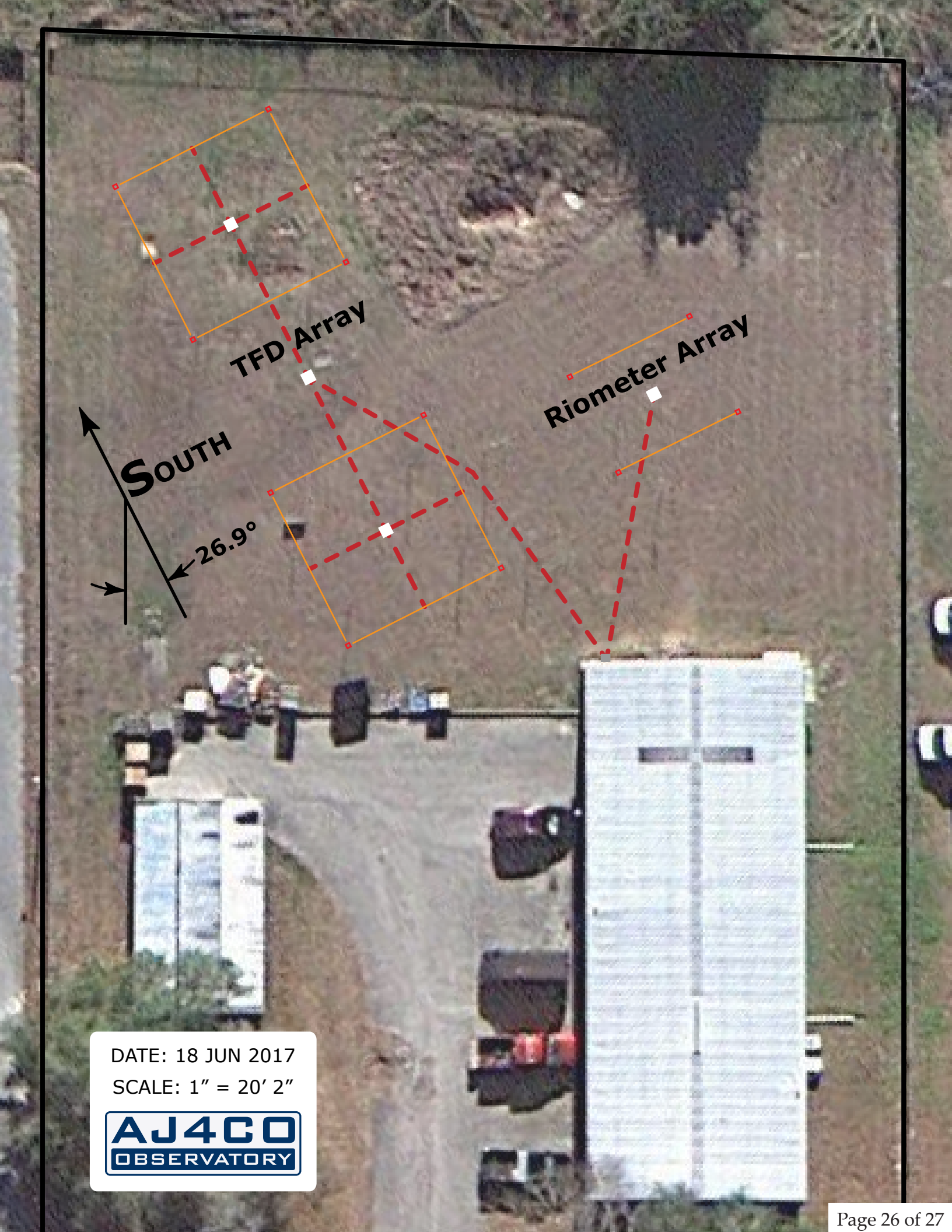

TFD Array

Riometer Array

SOUTH

26.9°

DATE: 18 JUN 2017
SCALE: 1" = 20' 2"



UFRO

AJ400
OBSERVATORY

LGM

